



Ministry of Housing
and Urban Affairs
Government of India



Swachh Bharat Mission - Urban

Advisory on On-Site and Decentralized Composting of Municipal Organic Waste



Central Public Health and Environmental
Engineering Organisation (CPHEEO)

MINISTRY OF HOUSING AND URBAN AFFAIRS

June 2018

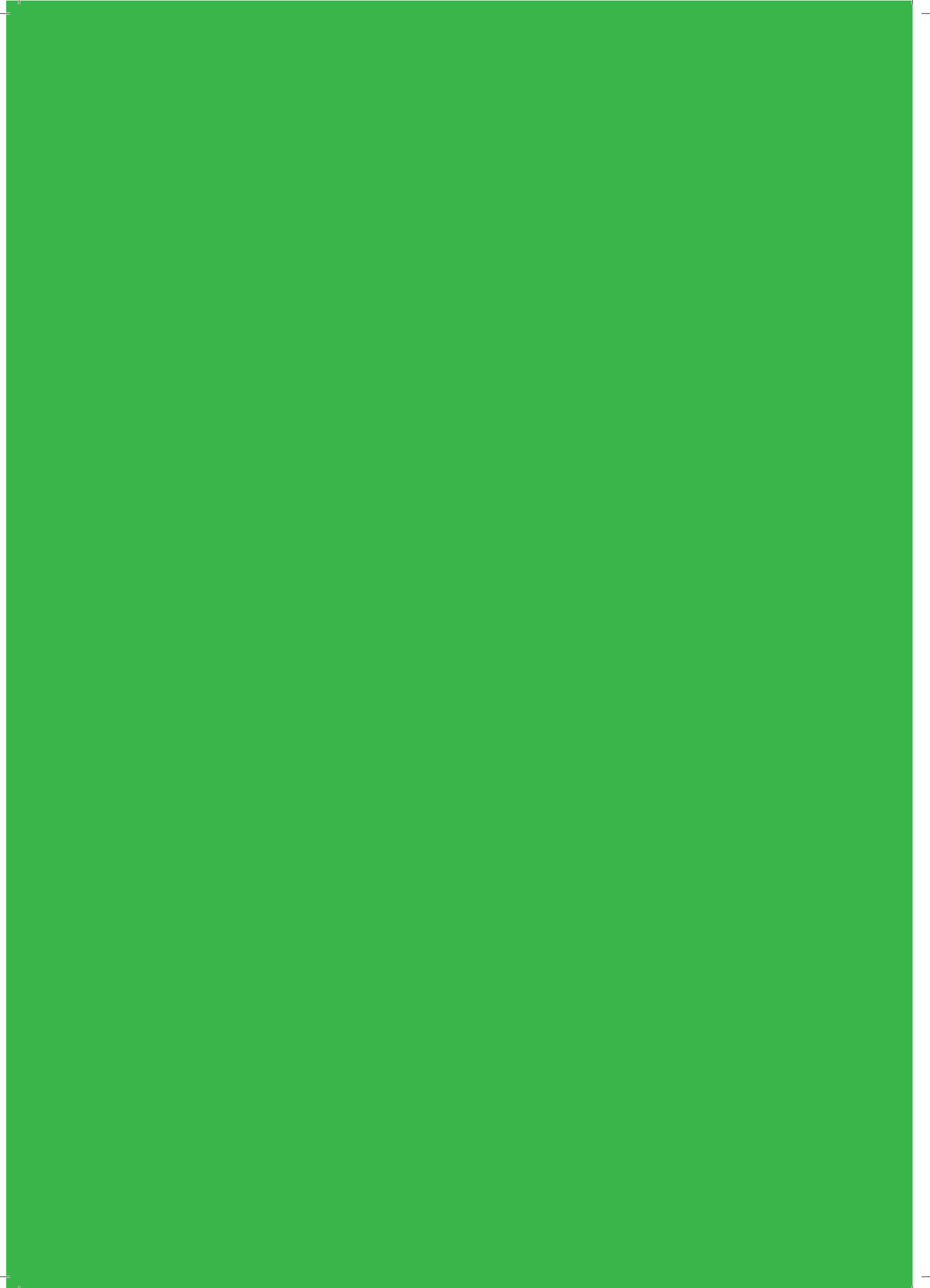



Ministry of Housing
and Urban Affairs
Government of India



Swachh Bharat Mission - Urban

Advisory on On-Site and Decentralized Composting of Municipal Organic Waste

Central Public Health and Environmental
Engineering Organisation (CPHEEO)

MINISTRY OF HOUSING AND URBAN AFFAIRS

www.mohua.gov.in

June 2018

DISCLAIMER

While utmost care has been taken in collecting the details of case studies and information given in this Advisory, it is made clear that any one desiring to replicate these processes/treatment methods shall make diligent enquiry on their suitability for specific requirement and usage. Ministry assumes no liability regarding the completeness, accuracy or adequacy of any process/treatment method mentioned, or for any loss which might arise out of adopting these for on-site and decentralised waste processing.



HARDEEP S PURI

Hon'ble Minister of State
(Independent Charge)
Ministry of Housing
& Urban Affairs

MESSAGE FROM HON'BLE MINISTER OF STATE (INDEPENDENT CHARGE)

हरदीप एस पुरी
HARDEEP S PURI



आवासन और शहरी कार्य
राज्य मंत्री (स्वतंत्र प्रभार)
भारत सरकार
MINISTER OF STATE (I/C)
HOUSING AND URBAN AFFAIRS
GOVERNMENT OF INDIA



Message from the Minister

Solid Waste Management Rules 2016 published by the Ministry of Environment, Forest & Climate Change, lay emphasis on decentralized waste management as an efficient, economical and sustainable option involving close stakeholder participation. The Ministry of Housing and Urban Affairs is taking various steps to create awareness about the decentralized solid waste treatment systems among various stakeholders including the ULBs. One such initiative is this advisory.

This advisory contains live case studies of several onsite and decentralized organic solid waste treatment methods and units being successfully implemented by various stakeholders. It is, therefore, practical and self-contained for replication.

The advisory will be useful not only for those who want to set up onsite decentralized solid waste treatment facilities but also for sanitation managers and administrators, academicians, students and other stakeholders interested in issues related to solid waste management. I believe this advisory is a firm step towards making our country clean.

I congratulate all the officers of CPHEEO and the Ministry, who were involved in the preparation of this advisory.

I urge all stakeholders to make use of this advisory in an effective manner and help the Government's initiative to make India swachh by 2 October 2019 when we celebrate the 150th birth anniversary of our Father of the Nation.

New Delhi
09 April 2018

(Hardeep S Puri)



DURGA SHANKER MISHRA

Secretary

Ministry of Housing
& Urban Affairs

FOREWORD FROM SECRETARY- HOUSING AND URBAN AFFAIRS

In order to reduce the burden of unscientific handling of large volumes of Municipal Solid Waste, the ULBs need to shift their focus from centralised ‘single stream’ collection and ‘dump/Landfill disposal’ system to ‘multiple stream’ collection and scientific onsite/decentralised ‘processing’ system. Based on the stream of waste and its generation, the appropriate method of treatment/technology and the scale of treatment units (community/Ward/Division/Zone/City level) have to be selected and implemented.

Organic or biodegradable waste, unlike the inorganic or non-biodegradable waste can primarily be treated at onsite or decentralised waste treatment facilities at lesser cost and more efficiently. The Solid Waste Management (SWM) Rules 2016 published by Ministry of Environment, Forest & Climate Change, emphasise on the adoption of decentralised waste management systems.

This advisory is brought out for enabling implementation of Solid Waste Management Rules 2016, to promote onsite and decentralised organic solid waste treatment systems in the Country. It covers about 32 such onsite and decentralised technologies currently implemented successfully. The advisory has been prepared as user friendly and practical, as far as possible, duly incorporating the user’s feedbacks and contact information for all the technologies listed.

The motto of this advisory is to bring about disruptive change in the current system of end of the chain waste treatment and make the onsite & decentralised organic solid waste treatment systems more common and adaptable. The described onsite and decentralised organic waste treatment methods may be used as references for the selection of the suitable method/practice by various stakeholders for managing their solid waste at source itself or as close to source as possible.

I hope that this advisory will encourage various stakeholders of solid waste management to actively adopt the onsite and decentralised organic solid waste treatment technologies and reduce the amount of biodegradable waste from contaminating other waste and also from reaching the landfill or any other disposal facilities.

List of Abbreviations

ADS - Air Density Separator

BIS - Bureau of Indian Standards

BOD – Bio-chemical Oxygen Demand

DAP – Diammonium phosphate

CFL - Compact Fluorescent Lamp

C:N ratio (or) C/N - Carbon to Nitrogen ratio

CPHEEO – Central Public Health and Environmental Engineering Organization

FAS - Free Air Space

FCO - Fertiliser Control Order

GHG – Green House Gases

HDPE - High-density polyethylene

HH – Households

ISWM - Integrated Solid Waste Management

MRF - Material Recovery Facility

MSW - Municipal Solid Waste

O & M- Operation and Maintenance

RPM- Rotations per Minute

SBM - Swachh Bharat Mission

STP - Sewage Treatment Plant

SWM - Solid Waste Management

Tbsp – Table spoon

TPD - Tonnes per Day

VFA - Volatile Fatty Acids

VOC - volatile organic compounds

Contents

Message from the Minister

Foreword

1.	Introduction	1
1.1	Solid Waste Management	1
1.2	3R Approach for Waste Minimization	1
1.3	Waste Generator Types	2
1.4	Waste Streams	3
1.5	Methods of Treating Municipal Organic Solid Waste	3
1.6	Factors Affecting Composting	5
1.7	Speeding up Composting	7
1.8	Compost Quality Standards for Sale of Compost	8
1.9	About the Advisory	10
1.10	Advantages of On-site and Decentralized Composting	10
1.11	Suitability of Technology	10
2.	Waste to Compost systems	13
2.1	Waste to Compost systems for Individual Households, Small Communities, Apartments etc. up to 10 Households	14
2.2	Waste to Compost systems for Medium Sized Communities, Apartments, RWAs - for 11 – 300 Households; medium sized Offices, medium Hotels, Resorts, medium Schools, Canteens, Marriage Halls	31
2.3	Waste to Compost systems for large Communities, Apartments, RWAs, high rise buildings for 301 – 1000 Households; Large Offices, Large Hotels, Large Schools	51

2.4	Waste to Compost systems for Decentralized plants for more than 1000 Households operated by ULBs / Institutions / Outsourced agencies	57
2.5	Nirmalaya	64
	End Note	68
Appendices		
	I. Bio-Medical Waste Management Rules, 2016 - SCHEDULE I	70
	II. Hazardous and Other Wastes (Management and Transboundary Movement) Rules, 2016 - SCHEDULE I	74
	III. Hazardous and Other Wastes (Management and Transboundary Movement) Rules, 2016 - SCHEDULE II	78
	IV. Hazardous and Other Wastes (Management and Transboundary Movement) Rules, 2016 - SCHEDULE III	85
	V. List of Technology and Service Providers in Onsite and Decentralized Solid Waste Management	98
	Bibliography	103

1. Introduction

1.1 Solid Waste Management

Municipal Solid Waste (MSW) is the trash or garbage that is discarded in day to day activities in a human settlement. The Solid Waste Management Rules, 2016 state:

Solid waste means and includes solid or semi-solid domestic waste including sanitary waste, commercial waste, institutional waste, catering and market waste and other non-residential wastes, street sweepings, silt removed or collected from the surface drains, horticulture waste, construction and demolition waste and treated biomedical waste excluding industrial hazardous waste, biomedical waste and e-waste generated in an area under urban local body.

Solid Waste Management (SWM) is the science associated with the management of solid waste using the best principles and practices of public health,

economics, engineering, conservation, aesthetics and other environmental considerations.

The Integrated Solid Waste Management (ISWM) system is based on the waste management hierarchy (see figure below), with the aim to reduce the amount of waste being disposed, while maximizing resource recovery and efficiency.

1.2 3R Approach for Waste Minimization

The 3R Approach is aimed at optimising Municipal Solid Waste (MSW) management in all the waste-generating-cum-waste management activities, involving all the stakeholders (waste generators, service providers, informal sector, regulators, government, and community or neighbourhoods). The adoption of 3R minimizes the waste being handled by the ULB and reduces the public health & environmental risks associated with it.

<p>MOST PREFERRED</p>  <p>LEAST PREFERRED</p>	<p>AT SOURCE REDUCTION AND REUSE</p>	Waste minimisation and sustainable use or multi use of products (e.g. Reuse of carry bags or packaging jars)
	<p>RECYCLING</p>	Processing non-biodegradable waste to recover Recycling commercially valuable materials (e.g. Plastic, paper, metal, glass, e-waste recycling)
	<p>COMPOSTING</p>	Processing biodegradable waste to recover compost (e.g. Windrow composting, in-vessel composting, vermi composting)
	<p>WASTE TO ENERGY</p>	Recovering energy before final disposal of waste (e.g. RDF, biomethanation, co-processing of combustible non-biodegradable dry fraction of MSW, incineration)
	<p>LANDFILLS</p>	Safe disposal of inert residual waste at sanitary landfills after recycling and reuse to the maximum extent possible.

Reduce

The concept of reducing waste generated by reducing consumption is essential to waste management hierarchy. The logic behind it is simple to understand – if there is less of waste generated, then there is less to recycle, reuse or to manage. The process of reducing begins with an examination of what is being used, what it is used for and how much it can be reduced. It also involves modification of process and packaging; substitution; minimization and elimination.

Reuse

The reuse of items (for multiple times) or re-purposing them for a use different from what they are originally intended for is the next essential thing in the waste reduction hierarchy. Items may be reused for one's own use (or reuse) or donated so that others can use them.

Recycle

The last stage of the 3R waste hierarchy is to recycle. To recycle means that the waste will be transformed into a raw material for manufacturing a new item. There are very few materials on the earth that cannot be recycled, hence it is very effective in waste management. Thus, the 3R approach lives at the very top of the waste management hierarchy.

1.3 Waste Generator Types

Based on the type of generator, MSW is classified into various categories, as given below:

Domestic

Household Waste - waste from kitchen, house cleaning, old papers, packing, bottles, crockery wares, furnishing materials, garden trimmings etc. generated in household and domestic settings.

Commercial

Waste generated at business premises, shops, offices, markets, departmental stores (paper, packing material, spoiled and discarded goods) organic, inorganic, chemically reactive and hazardous waste;

Institutional

Waste generated from Schools, Colleges, Hospitals, Hotels and Restaurants, Markets selling vegetables, fruits, fish/meat etc., Community Halls, Religious places, Function areas etc.

Industrial/Trade

Waste generated from manufacturing and material processing activities.

Construction & Demolition Waste

Waste comprising of building materials, debris and rubble resulting from construction, re-modeling, repair and demolition of any building/structure.

Bio-Medical

Any waste, which is generated during the diagnosis, treatment or immunisation of human beings or animals or research activities thereto or in the production or testing of biological materials or in health camps, including the categories mentioned in Schedule I appended to Bio-Medical Waste Management Rules, 2016.

Hazardous

Any waste which by reason of its characteristics such as physical, chemical, biological, reactive, toxic, flammable, explosive or corrosive nature, causes danger or is likely to cause danger to health and/or environment, whether by itself or in contact with other wastes or substances, and shall include -

- (i) waste specified under column (3) of Schedule I of Hazardous and Other Wastes (Management and Transboundary Movement) Rules, 2016;
- (ii) waste having equal to or more than the concentration limits specified for the constituents in class A and class B of Schedule II or any of the characteristics as specified in class C of Schedule II of Hazardous and Other Wastes (Management and Transboundary Movement) Rules, 2016; and
- (iii) wastes specified in Part A of Schedule III in respect of import or export of such wastes or the wastes not specified in Part A but exhibit hazardous

characteristics specified in Part C of Schedule III of Hazardous and Other Wastes (Management and Transboundary Movement) Rules, 2016;

Sewage

Sewage is the liquid waste containing faecal matter excreted by humans along with washing water, urine, laundry waste and other such waste discharges.

1.4 Waste Streams

Organic/Biodegradable waste (Wet Waste)

Means any organic material that can be degraded by micro-organisms into simpler compounds.

Non- biodegradable waste (Dry Waste)

Means waste other than biodegradable waste and inert street sweepings and includes recyclable and non-recyclable waste and combustible waste.

Inert Waste

Wastes which are not bio-degradable, recyclable or combustible such as street sweepings or dust and silt removed from drains;

Sanitary waste

Means wastes comprising of used diapers, sanitary towels, napkins, condoms, incontinence sheets and any such similar waste.

Domestic Hazardous waste

Means discarded paints and pesticide containers, CFL bulbs, tube lights, medicines, broken mercury thermometers, used batteries, used needles, blades & syringes and contaminated gauze etc. generated at the household level.

1.5 Methods of Treatment of Organic Solid Waste

Municipal Solid Waste (MSW) primarily consists of biodegradable, non-biodegradable and inert fractions. Biological or thermal treatment of biodegradable and non-biodegradable waste can lead to recovery of useful products such as compost or energy.

Biological treatment of biodegradable (organic) waste involves using micro-organisms to decompose the biodegradable components of waste into useful products. Biodegradable waste can be decomposed in two ways:

- Aerobic processes (in the presence of oxygen), and
- Anaerobic processes (in the absence of oxygen)

In the aerobic process the utilizable product is compost. In the anaerobic process the utilizable product is methane gas (for energy recovery) and sludge, which can be composted. The Municipal Solid Waste Management Manual 2016, CPHEEO, published by the Ministry describes various treatment/processing methods of solid waste which can be used at Urban Local Body (ULB) level.

Aerobic Composting

Aerobic composting is the process of aerobic decomposition of biodegradable organic matter in a warm, moist environment by the action of bacteria, yeasts, fungi and other organisms. During aerobic composting, microorganisms oxidize organic compounds to compost (humus), carbon dioxide (CO₂) and water vapour with the release of energy (heat).



The aerobic composting can be further divided into

- Conventional Windrow Composting
- Rapid Composting
 - Vermi-composting (using earthworms for composting)
 - Mechanical Composting (using mechanical equipment for composting)

Compositing requires approx. 25 m² area per tonne of MSW (only for windrow formation for 21 days composting and maturity yard for 30 days stabilization). Additional area required is for machinery, packing and storage. Facilities are also required for recycling and treatment of effluent (leachate) and sanitary landfill for rejects (compost rejects and inert materials).

Vermicomposting is the process of treating organic wastes through earthworms. It is a natural, odourless, aerobic process, much different from traditional composting. Earthworms ingest waste and after digestion, the undigested material moves through the alimentary canal of the earthworm, wherein a thin layer of oil is deposited on the castings. The process in the alimentary canal of the earthworms transforms organic waste to natural fertilizer. The chemical changes that the organic wastes undergo include deodorizing and neutralizing. The result is that the pH of the castings is 7 (neutral) and the castings are odorless. The worm castings also contain bacteria, so the process is continued in the soil, and microbiological activity is promoted. The castings contain high amounts of nitrogen, potassium, phosphorus, calcium, and magnesium. Several researchers have demonstrated that earthworm castings have excellent aeration, porosity, structure, drainage, and moisture-holding capacity. The content of the earthworm castings, along with the natural tillage by the worms burrowing action, enhances the permeability of water in the soil. Vermicomposting can be done in a tank of size 4m x 1m x 0.5m for waste input of 10kg/day of semi decomposed waste. Species of earthworms that are commonly found in India are *Eisenia foetida*, *Amyanthes diffrigens* and *Eudrillus engineac*.

Depending upon the types of organic waste, the contents of plant nutrients vary in the vermin compost. However, a typical vermicompost has the following fractions of plant nutrients:

Nitrogen- 1.5 – 2.5 %; Calcium- 0.5 – 1.0 %; Phosphorus- 0.9 – 1.7 %; Magnesium- 0.2 – 0.3 %; Potash- 1.5 – 2.4 %; Sulphur- 0.4 - 0.5 %; and other micronutrients with enzymes & hormones.

Anaerobic Composting/Digestion or Biomethanation

It is a process based on anaerobic digestion of organic matter in which microorganisms break down

biodegradable material in the absence of oxygen to produce biogas which can be used as fuel. Biogas consists primarily of methane (CH_4) and carbon dioxide (CO_2), but can also contain significant concentrations of hydrogen sulphide (H_2S) and trace quantities of siloxanes and various volatile organic compounds (VOCs). In addition to the gases, there will be solid or semi-solid (sludge) and liquid (liquor) material leftovers after anaerobic digestion. The sludge can be composted and used as fertilizer, whereas the liquor can be treated in STP and also used for recycling purposes. The process is ideal for treating homogenous organic waste. Fibrous organic matter is undesirable as the anaerobic microorganisms do not easily break down woody molecules such as lignin, cellulose, hemicelluloses, etc. Area requirement for bio-methanation is approximately 25 m² per tonne of MSW. Extra area is required for machinery, gas containing and storage facilities.

The moisture content at which an anaerobic digester is designed to operate is the most important criteria for the process technology to perform for a given feedstock mix. This criteria determines the basic design parameters for the digester vessel, conveyance systems, feedstock preparation systems, and sludge handling systems. It also affects operating costs, with higher moisture contents generally incurring greater costs. Based on the moisture content at which a digester is designed to operate, the digesters are divided into two types i.e., (a) wet (low solids) digesters (moisture content greater than 80%) and (b) high-solids digesters (moisture content lesser than 80%). Further, the high-solids digesters can be divided into stackable/deposition type (moisture content is less than 60%) and slurry type (moisture content 60-80%).

Wet digesters are designed to handle waste materials dissolved or suspended in water. A wet digester vessel is a stirred tank. In high-solids digesters, the materials are either pumped into digester tank as a slurry or stacked in place. When stacked in place, water is percolated through the waste materials to distribute nutrients and

microorganisms; they are not submerged in the tank.

Digesters can also be configured as single-stage, two-stage or multi-stage systems. Most digesters are single-stage, with the entire biological digestion process taking place in a single vessel. In two-stage systems, the first and second stages of the process occur in two different vessels, which are optimized for the microorganisms,

active in each digestion stage. Multi-stage digestion systems (i.e., more than two stages) are used for other waste types, but MSW organic digesters are generally restricted to two stages.

1.6 Factors Affecting Composting

The key factors affecting the composting and digestion processes are described below:

Sl. No.	Factors	Optimal range during various stages			Remarks
		Active composting	Curing	Product storage	
1.	Oxygen concentration	13 to 18%			Maintaining higher oxygen concentration in a compost pile is difficult and may actually lead to other problems, like low moisture content.
2.	Free Air Space (FAS)	40 to 60%			There must be enough void space in the compost pile for oxygen availability.
3.	Particle Size	A mixture of particles between 3 and 50 mm		Minimum 90% material should pass through 4.0 mm IS sieve	Smaller particles have a greater surface area relative to their volume, which means more of the material is exposed to microorganisms. However, too smaller particles adversely affect the FAS within the material.
4.	Structure	Enough of the particles in the composting pile maintain their structural properties throughout the composting process.			If all of the particles have poor structural characteristics (like cardboard, which becomes wet and loses its initial rigidity), the FAS within the composting pile is reduced.
5.	C:N ratio	25:1 to 30:1	18:1 to 23:1	15:1 to 20:1	If C:N ratio is less than the available carbon may be fully consumed before all the nitrogen is stabilized, and the balance nitrogen can be converted to ammonia and lost as a gaseous emission. If the C:N ratio is higher, the composting process proceeds at a slower pace, since the microorganism's population size is limited by the lack of nitrogen.
6.	Moisture content	55 to 65%	45 to 55%	15 to 25%	If moisture levels are too low (i.e., less than 40%), the size and activity level of the microorganism populations is inhibited, resulting in slower composting and/or curing. When moisture levels are too high (i.e., more than 65%), there is a risk that too much of the pore space between individual particles fills with water, which can lead to anaerobic conditions and unpleasant odours. Higher moisture levels can also lead to excess moisture draining out of the composting pile as leachate.

7.	Temperature	55° to 60°C	Less than 50°C	Ambient	Too high temperature for sustained periods (greater than about 65°C), rapidly declines the population of beneficial microorganisms. Too low temperatures can allow less efficient microorganisms to become predominant resulting in slower composting.
8.	pH	6.5 to 8		6.5 - 7.5	Microorganisms cannot survive in environments that are too acidic or alkaline. Also, when the pH is greater than 9, nitrogen is more readily converted to ammonia and becomes biologically unavailable, increasing the C:N ratio and slowing the process.

Anaerobic digestion

Sl. No.	Factors	Optimal range for various types of digesters			Remarks
		High-solids		Low solids	
		Stackable	Slurry		
1.	Moisture content	Less than 60%	Between 60 to 80%	Greater than 80%	The system will not work if the moisture content is not in the right range.
2.	pH	6.0 to 7.0 ^a			Low pH slows down the process and may lead to the death of microorganisms.
3.	Alkalinity	More than 100 mg/L			Even a little alkalinity will speed the acidogenic stage faster than the methanogenic stage, which can lead to process upsets.
4.	Volatile Fatty Acids (VFAs)	Less than 4000 mg/L			Higher concentrations of VFAs can be toxic to the microorganisms in the digester.
5.	Temperature	Mesophilic digesters: 30° to 38°C Thermophilic digesters: 50° to 60°C			Thermophilic breakdown proceeds much faster than mesophilic. Therefore, thermophilic reactor can yield a higher rate of biogas production in a shorter period of time.
6.	Retention time (SRT)	14 to 40 days ^b			If the SRT is too short, the full degradation process will not be achieved. If the SRT is too long, biogas recovery efficiency suffers, and the digester vessel will not be efficiently used.
7.	C:N Ratio	30:1			Excess nitrogen can lead to the accumulation of ammonia in the digester. Lower nitrogen can affect the cell growth of microorganisms.
8.	Ammonia	200 mg/L			Excess ammonia leads to substrate/product toxicity and hampers the digestion process.
9.	Sulphide	Less than 50 mg/L			presence of high sulphide (as H ₂ S) levels inhibits methane generation, which is most likely due to high loading of sulphur compounds, including proteins.

Notes:

- ^a Typical range for single-stage digester. In two-stage digesters, typical range is 5.0 to 6.0 in hydrolysis/acid-forming stages (first digester) and 6.5 to 8.0 in methanogenic stage (second digester).
- ^b Depends strongly on technology;
- C:N – carbon to nitrogen
- mg/L—milligrams per litre

1.7 Speeding up Composting – Alternative Sources of Culture/Bioculum/Inoculum

Most of the microorganisms for composting are readily available in the MSW itself and they tend to multiply rapidly in favourable conditions. Further, the number of bacteria is rarely a limiting factor in composting, provided all other (above mentioned) factors are appropriate. However, there are various inoculums available in the market claiming to hasten the composting process. Following are some of the locally available materials which can be used as alternatives to the commercially patented inoculums.

a) Cow dung:

Fresh cow dung may be used as alternative for patented inoculum/bioculum/culture. The ratio of mixing varies with the characteristics of the waste material to be treated. Cow dung added in excess to the waste will not affect the quality of the compost. However, care is to be taken to maintain the moisture content of the overall mixture at 45% to 55% by weight, for aerobic digestion.

In some cases, additives such as Urea/DAP are added to the waste cow dung mixture to maintain the C/N ratio. For 1000 kg microbial enriched compost production, the quantity of fresh waste material, cow dung and urea required will be 1600, 320 and 21 kg, respectively.

In anaerobic digestion, the cow dung will be added in slurry form for initial seeding. The slurry can be made by mixing fresh cow dung with water in the ratio of 1:1. Sometimes other additives like jaggery, yeast etc. will be added to the slurry, based on the requirement.

b) Sour Buttermilk/Curd:

Sour buttermilk/curd can be used to accelerate the aerobic composting. The ratio of sour buttermilk/curd to that of the waste varies with the characteristics and quantity of the waste material to be treated. Care is to be taken to maintain the moisture content of the overall

mixture at 45% to 55% by weight, for aerobic digestion.

c) Sludge of Sewage Treatment Plants (STPs) and digesters:

The sludge of the STPs and digesters can be used as source of microorganisms in aerobic/anaerobic composting processes. However, it may be noted that the sludge from the STPs which uses aerobic treatment processes will be useful only for aerobic composting process and the sludge of the digester will be only useful for seeding the anaerobic processes. Care may be taken to maintain the moisture content of the overall mixture at 45% to 55% by weight, for aerobic digestion.

d) Panchagavya

Panchagavya, an organic concoction has the potential to promote growth and providing immunity in plant systems. Panchagavya consists of nine ingredients viz. cow dung, cow urine, milk, curd, jaggery, ghee, banana, Tender coconut and water.

Mix 7 kg Cow dung and 1 kg Cow ghee thoroughly both in morning and evening hours and keep it for 3 days. After 3 days, mix 10 L of cow urine & 10 L of water with the mixture and keep it for the next 15 days with regular mixing both in morning and evening. After 15 days, mix the following and panchagavya will be ready after another 30 days.

- Cow milk - 3 litres
- Cow curd - 2 litres
- Tender coconut water - 3 litres
- Jaggery - 3 kg
- Well ripened banana – 12 nos.

e) Compost Inoculant developed by Indian Agricultural Research Institute (IARI), New Delhi-110012 (popularly called PUSA Institute)

IARI, Pusa Road, New Delhi has developed an inoculum of consortium of microbes (extracted from cow dung) to accelerate the process of composting. This microbial consortium made in the labs at Pusa has a mix of

thermophilic and mesophilic bacteria. Since IARI makes it only for demonstration purposes, a sample can be obtained by request to the division of Microbiology. This consortium can be used for small scale composting only. IARI also states that same microbes are present in air hence waste decomposition can happen even without the inoculum.

On the other hand, there are several Composting inoculants available at varying prices in the market making many claims. Users are unsure of claims made by the inoculant vendors. IARI at Pusa can carry out scientific experiments for comparative performances of inoculants available in the market, with IARI inoculate as a baseline. The lab in Pusa also has facilities to carry out quality testing of city compost as per FCO norms.

IARI Training on Composting at Pusa Institute

Dr. S.D. Mishra and his team at IARI provide entrepreneurs interested in composting with the technical knowhow to run a business. This technical know-how is disseminated through a 3-5 day training programme run on fee

basis. The course is in lecture-cum-practical format covering the production and utilization of different kinds of compost (vermicomposting, windrows, machine composting, microbial culture for composting, etc.) along with best practices such as Terrace Gardening, Kitchen Gardening, management of Park, Institutional, Mandi and Household Waste, Tips for Segregation, Different models of composting customized for different income segments, etc.

Contact Details:

Dr. Siva Dhar Mishra
Principal Scientist (Agronomy)
Indian Agricultural Research Institute (IARI)
Pusa Road, New Delhi-220012
Phone: +91-11-25842902 (O)
Email: drdmisra@gmail.com

1.8 Compost Quality Standards

Compost Quality Standards as per Solid Waste Management Rules, 2016; Fertiliser Control Order, 2009; and Fertiliser Control Order, 2013

Sl. No.	Parametres	Organic Compost FCO 2009	Phosphate Rich Organic Manure FCO (PROM) 2013
1.	Arsenic (mg/kg)	10.00	10.00
2.	Cadmium (mg/kg)	5.00	5.00
3.	Chromium (mg/kg)	50.00	50.00
4.	Copper (mg/kg)	300.00	300.00
5.	Lead (mg/kg)	100.00	100.00
6.	Mercury (mg/kg)	0.15	0.15
7.	Nickel (mg/kg)	50.00	50.00
8.	Zinc (mg/kg)	1000.00	1000.00
9.	C/N ratio	<20	less than 20:1
10.	pH	6.5 - 7.5	(1:5 solution) maximum 6.7
11.	Moisture, % by weight, maximum	15.0-25.0	25.0
12.	Bulk density (g/cm ³)	<1.0	Less than 1.6
13.	Total organic carbon, % by weight, minimum	12.0	7.9

14.	Total nitrogen (N), % by weight, minimum	0.8	0.4
15.	Total phosphate (P ₂ O ₅), % by weight, minimum	0.4	10.4
16.	Total potassium (K ₂ O), % by weight, minimum	0.4	–
17.	Colour	Dark brown to black	–
18.	Odour	Absence of foul odour	–
19.	Particle size	Minimum 90% material should pass through 4.0 mm IS sieve	Minimum 90% material should pass through 4.0 mm IS sieve
20.	Conductivity (as dsm-1), not more than	4.0	8.2

Note: Tolerance limits as per FCO:
 For compost- A sum total of nitrogen, phosphorus and potassium nutrients shall not be less than 1.5% in compost
 For PROM- No such directive

Vermi-Compost Standards as per Fertilizer Control Order, 2009

Sl. No	Criteria	Value
1.	Moisture % by weight	15.0–25.0
2.	Colour	Dark brown to black
3.	Odour	Absence of foul odour
4.	Particle size	Minimum 90% material should pass through 4.0 mm IS sieve
5.	Bulk density	0.7–0.9
6.	Total organic carbon, % by weight, minimum	18.0
7.	Total nitrogen (N), % by weight, minimum	1.0
8.	Total phosphates (P ₂ O ₅), % by weight, minimum	0.8
9.	Total potash (K ₂ O), % by weight, minimum	0.8
10.	Heavy metal content (mg/kg) by weight, maximum	
	a. Cadmium (Cd)	5.00
	b. Chromium (Cr)	50.0
	c. Nickel (Ni)	50.0
	d. Lead (Pb)	100.0

Note: Tolerance Limit for vermicompost:
 The sum total of Nitrogen, Phosphorus and Potassium nutrients should not be less than 2.5 % in the case of vermicompost.

1.9 About the Advisory

Solid Waste Management Rules 2016 published by Ministry of Environment, Forest & Climate Change, lay emphasis on decentralised waste management. Therefore, to create awareness of decentralised waste treatment systems and to generate competitive waste management among the cities under Swachh Bharat Mission (SBM), greater stress is being laid on the installation of decentralised treatment facilities and distinct scoring marks have been allocated towards the same in Swachh Survekshan 2018 and in future also.

With this in view, this advisory is being published by the Ministry to throw light on several onsite and decentralised organic treatment methods and units currently being used. The decentralised treatment processes have been classified into four categories based on the number of households while considering organic waste generation as 100-200 gm/capita/day, out of the total waste generation of about 400-450 gm/capita/day.

The waste to compost systems have been categorized as in the table below depending upon their capacity of treatment:-

Sl. No.	Category	No. of Households	Suitability
1.	Category – 1	Up to 10 Households	Individual Households, small Communities, Apartments etc.
2.	Category – 2	11 – 300 Households	Medium sized Communities, Apartments, RWAs, medium sized Offices, medium Hotels, Resorts, medium Schools, Canteens, Marriage Halls
3.	Category – 3	301 – 1000 Households	Large Communities, Apartments, RWAs, high-rise buildings, large Offices, large Hotels, large Schools
4.	Category – 4	Above 1000 Households	Decentralized Composting plants operated by ULBs/Institution/ Outsourced agency

The subsequent pages of this advisory provide details on some of the onsite and decentralised organic waste treatment methods. This can be used as a ready reference by various stakeholders for managing their solid waste at source itself and in decentralised manner.

1.10 Advantages of Decentralised Composting

1. Reduction in the collection and transportation chain of MSWM and costs thereof.
2. Reduction in GHG emissions due to uncontrolled putrefaction /decay of biodegradable waste due to extended collection and transportation chains.
3. Reduction in smell/bad odour at the premises / storage points and roads & streets.
4. Elimination of uncontrolled leachate.
5. Shorter the collection & transport chain, better the quality of City compost.
6. Decentralised City compost producers are more likely to use the compost themselves or develop strong off-take arrangements.

1.11 Suitability of Method/Technology of composting for the quantity of Organic Waste Generated

The table on next page gives the gist of suitability of various onsite and decentralised composting methods discussed in this advisory, for various sizes of households and other premises/establishments. However, any methods for handling smaller capacity of waste can be used to handle more waste simply by increasing the number of units. In such cases, it is recommended to work out the cost comparisons and space requirements before selecting an appropriate method according to the need and financial capacity.

S.No.	Name of the Technology	Suitability			
		Individual Households, Small Communities, Apartments etc. up to 10 Households	Medium Sized Communities, Apartments, RWAs - for 11 – 300 Households; medium sized Offices, medium Hotels, Resorts, medium Schools, Canteens, Marriage Halls	Large Communities, Apartments, RWAs, high rise buildings for 301 – 1000 Households; Large Offices, Large Hotels, Large Schools	Decentralized plants for above 1000 Households operated by ULBs / Institutions / Outsourced agencies
1	Pit Composting	✓	×	×	×
2	Pot Composting	✓	×	×	×
3	Tri Pot Composting	✓	×	×	×
4	Bio Composter	✓	×	×	×
5	Ring Composting	✓	×	×	×
6	Kitchen Bin Composting	✓	×	×	×
7	Mose Pit Composting	✓	×	×	×
8	Blue HDPE Digester	✓	×	×	×
9	Ecopot	✓	×	×	×
10	Drum Composting System	✓	✓	×	×
11	Rotary drum composting (Small)	✓	×	×	×
12	Composting Basket/Bin	✓	×	×	×
13	Vermi Composting	×	✓	×	×
14	Portable Household Bio Bin	×	✓	×	×
15	Aerobic Bin Composting	×	✓	×	×
16	Centralised Masonry Biotank Composting	×	✓	×	×
17	Organic Waste Composting Machine	×	✓	✓	×
18	Byobin	×	✓	×	×
19	Orbin	×	✓	×	×
20	Solar Composter	×	✓	×	×
21	Aaga	×	✓	×	×
22	Bokashi	×	✓	×	×
23	Plastic crates	×	✓	×	×

S.No.	Name of the Technology	Suitability			
		Individual Households, Small Communities, Apartments etc. up to 10 Households	Medium Sized Communities, Apartments, RWAs - for 11 – 300 Households; medium sized Offices, medium Hotels, Resorts, medium Schools, Canteens, Marriage Halls	Large Communities, Apartments, RWAs, high rise buildings for 301 – 1000 Households; Large Offices, Large Hotels, Large Schools	Decentralized plants for above 1000 Households operated by ULBs / Institutions / Outsourced agencies
24	Steel Mesh Composter	×	✓	×	×
25	FRP Aerobic Digester	×	✓	×	×
26	Wet Waste Composter	×	✓	×	×
27	Marigold	×	×	✓	×
28	Soil and Health SWM consultant aerobic and anaerobic composter	×	×	✓	×
29	Large Scale Composting Pits	×	×	✓	×
30	Windrow Composting	×	×	×	✓
31	Rotary Drum composting (Large)	×	×	×	✓
32	Vermi Composter	×	×	×	✓
33	Tallboy	×	×	×	✓
34	Temple Flowers Waste Recycling to Agarbatti Making				

2.

Waste
to Compost
Systems

2.1: Waste to Compost systems for Individual Households, Small Communities, Apartments etc. up to 10 Households

1. Pit Composting
2. Pot Composting
3. Tri Pot Composting
4. Bio-Composter
5. Ring Composting
6. Kitchen Bin Composting
7. Mose Pit Composting
8. Blue HDPE Digester
9. Eco Pots
10. Drum Composting
11. Rotary Drum Composting (Small)
12. Composting Basket/Bin

1. Pit Composting

SI No	Description
1	<p><u>Specification and Size</u></p> <ul style="list-style-type: none"> • Pits of adequate size to bury bio-degradable waste continuously for about 6 months in each pit. • Pit size of length of 1m and width 60 cm and depth 1m for a family of 5 or 6 members. Bigger size pits for bigger families according to requirements.
2	<p><u>Infrastructure Requirements</u></p> <ul style="list-style-type: none"> • Two pits of adequate size to be dug. • Tarpaulin or PVC roofing sheets to cover the pits. • Cow-dung, loose earth. • Tools like shovel, hoe etc.
3	<p><u>Operation & Maintenance</u></p> <ul style="list-style-type: none"> • Choose an elevated area where water does not get collected. Otherwise make necessary provisions to prevent entry of water into the pit by constructing a small bund around the pits. • Spread a layer of cow dung slurry or decomposed waste at the bottom of the pit before filling the waste for composting. • Spread the waste over the cow dung or decomposed waste layer. • Waste of bigger sizes are to be cut into small pieces for easy decomposing. • A thin layer of earth may be sprinkled over the waste daily to avoid bad smell from the pit. • Repeat the procedure daily while depositing more waste. • Once the pit is filled, close the pit by spreading a layer of 15cm of earth. • Once the first pit is closed, use the other pit in the same way. • The waste in the first pit becomes compost after a period of 4 to 6 months, empty the pit and make it ready for use. The compost can be used either as manure or sold or disposed-off in suitable manner. • Protect the pit from rain water. Keep it covered by means of tarpaulin or PVC roofing sheet during rains.

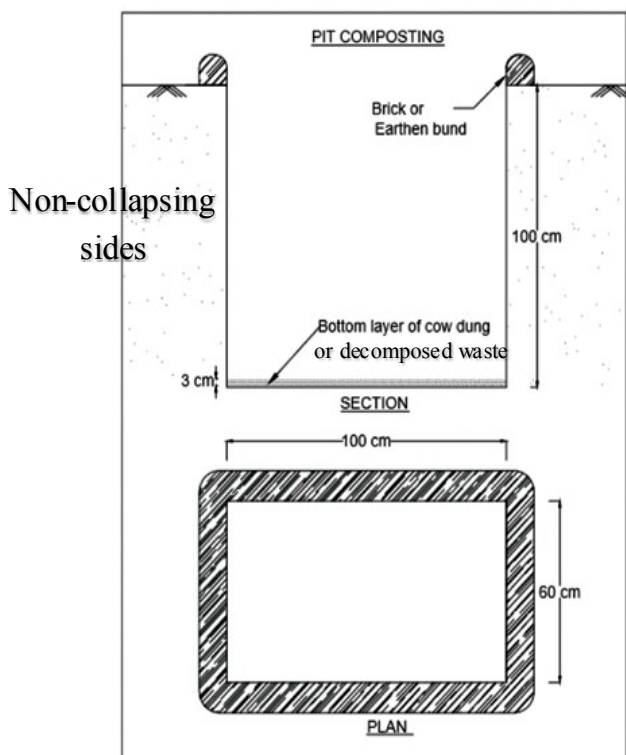

Section and Plan of Pit for Composting

USER'S FEEDBACK

Name of the Unit: Pit Composting Unit
 Place of the installation: Lal Bagh, Bangalore
 Year of installation: 2014
 Expenditure incurred at beginning: Rs. 2.5 lakh for digging and preparation of pit
 Coverage: 240 acres area of the park
 Biodegradable waste treated per day: 700 kg
 Processing Time: 4-5 months
 O& M cost: Nil (staff costs not included)
 Usage of Compost: Used within the garden
 Do's & Don'ts: cow dung slurry should be spread; appropriate moisture content should be maintained.
 Contact Details: Mr. Chandrashekhar, chandshekhar01@gmail.com

2. Pot Composting

SI No	Description	Unit Cost
1	<p><u>Specification and Size</u></p> <ul style="list-style-type: none"> • Mud pots - country burnt about 50cm height and about 35cm diameter at the centre with lid covers – 2 nos • Tripod stand 50cm high of appropriate design made of steel/ wood/ plastic or steel/ brick pedestals for keeping the pots – 2 nos. 	Rs.500/-
2	<p><u>Infrastructure Requirements</u></p> <ul style="list-style-type: none"> • Plastic vessel 10cm high and half litre capacity, for collecting leachate coming out of the pots – 1 No • Trowel small size – 1 No • Painting brush – ½ size – 1 No • 1 brick cut into 2 pieces • Plastic covers – 2 Nos 	
3	<p><u>Operation & Maintenance</u></p> <ul style="list-style-type: none"> • Make a small hole at the bottom of the pots. • Place the pots (with lids) on the tripods at a convenient place. • Place the half litre capacity plastic vessel below the first pot. • Start filling the segregated bio degradable waste (do not put slow degrading items and non- bio degradable items into the pots) daily into one pot and keep the pot closed. This type of waste treatment is capable of treating 1 to 2 Kg of waste per day only. • Leachate coming out of the pot gets collected in the plastic vessel placed below the pot. Put some salt powder into the plastic vessel to avoid of flies in the vessel. The leachate collected can be diluted with water and used as manure for trees and plants. • Once the first pot is full, start using the second pot • By the time the second pot becomes full the waste in the first pot gets converted into compost. • After first week of commencement, lot of worms will be seen in the pot. Do not try to kill them, they activate the composting process and they die after 3 weeks. • During rainy season spread the plastic sheets over the pots and place the brick pieces over the sheet to protect the pots from rains. • If the quantity of the water inside the pot is more, add some saw dust to absorb the water. • If too many flies are seen around the pot, make a solution of camphor in coconut oil (dissolve 2 tablets in 25ml of oil) and apply it on the pot and top cover with the brush. • Sprinkling diluted curd or cow dung solution etc. into the waste will speed up the composting process. 	

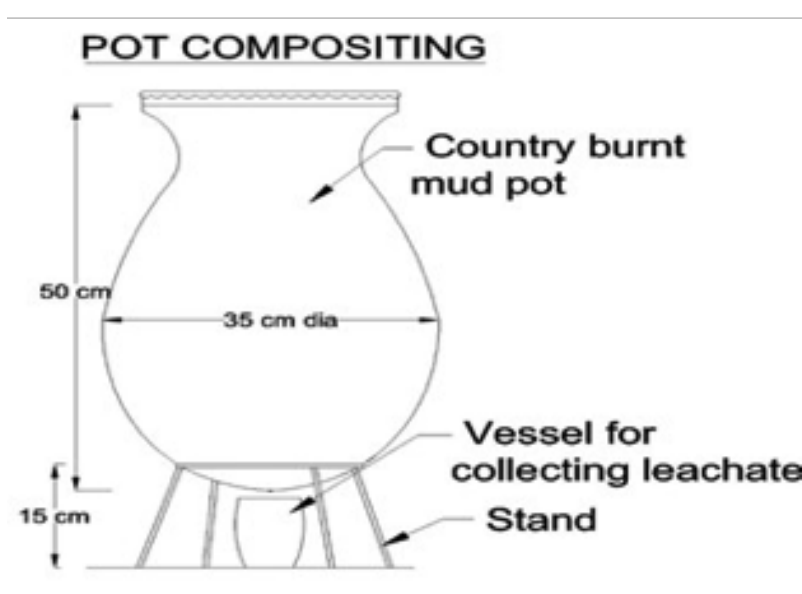

Pot Composting

USER'S FEEDBACK

Name of the unit: Pot Composting

Place of the installation: Maurya Enclave, Delhi

Year of purchase: 2016

Coverage: Individual Household

Biodegradable waste treated per day: 0.5 kg

Compost production: 1.0 kg per pot (each pot will consume up to 5-7 kg of waste)

Processing time: 60-75 days

Cost of unit: Rs. 120/pot

O & M cost: Negligible

Usage of compost: Used for home gardening

Do's & Don'ts: Chop the waste for speedy composting, moisture content should be maintained properly, turn the waste thoroughly at least once in two days for oxygen supply; cover the everyday's waste with a layer of soil/compost; non-veg. food items should be avoided; it is advantageous to add little sour buttermilk.

Contact details of the user: Ms. Kavinya, e-mail: kavinya.sk@gmail.com

3. Tri Pot Composting

SI No	Description	Unit Cost
1	<u>Specification and Size</u> <ul style="list-style-type: none"> • The set of pots and lid are locally moulded with clay/terracotta and oven dried. • To be kept vertically one above the other and the pot on the top is covered with the lid. • The pot number 1 and 2 are kept at the top and middle position and are open at top as well as at bottom. The bottom open portion is provided with weaved plastic wires. • Pot number 3 is kept at the bottom and is open at the top and closed at the bottom. 	Rs.1500/- to Rs. 3000/- per set
2	<u>Infrastructure Requirements</u> <ul style="list-style-type: none"> • Clay pots of 30cm internal diameter and 30cm high each – 3 Nos. • Earthen lid cover for top pot – 1 No. • Old news papers • Hand pump (sprayer) • Bio – compost or saw dust specially prepared with bio – culture. • Steel fork. 	

3

Operation & Maintenance

- Place newspaper sheets at the bottom of pot numbers 1 and 2 over the plastic woven wires to form a bio-platform.
- Spread starter material in 1 inch thick layer over the bio-platform (either prepared bio-compost or saw dust treated with bio-culture be used as starter material. Mix saw dust with diluted bio-culture (bio-culture, water ratio 1:50) and keep it in a sack bag duly tied. After two days, saw dust mixture becomes hot by the activities of the bacteria. This hot mixture can be used as the starter.
- Spread the shredded waste over the starter layer and spray diluted bio-culture mixture over the waste.
- Before closing the pot with the lid, sprinkle starter mixture over the waste layer. Ensure water used for mixing the bio culture does not contain chlorine - for that keep tap water in an open vessel for two days and use it.
- Keep spreading the waste daily as above.
- Third day onwards stir/mix the old waste layer by using a fork without tearing the paper at the bottom, before placing fresh waste on the top.
- Each time, spray bio-culture mixture and sprinkle starter over it before closing the lid.
- Once the top pot is full, shift the middle pot to the top and the top pot to the middle and repeat the process of spreading the waste in the new pot on the top in the same way as done earlier.
- Once the second pot also becomes full, tear off the paper layer in the first pot (now in the middle position) and push the semi-decomposed waste into the bottom pot.
- Shift the emptied pot to the top position and the top pot to the middle position. Continue filling the waste into the top pot in the same manner as done earlier.
- When all the pots are full, the waste inside the bottom pot will have become compost and ready for use as manure in gardens. Empty it and continue the process as a routine.
- Do not use excess water.
- This type of composting is suitable for a family of 4 to 5 members, generating 2 kg waste per day.

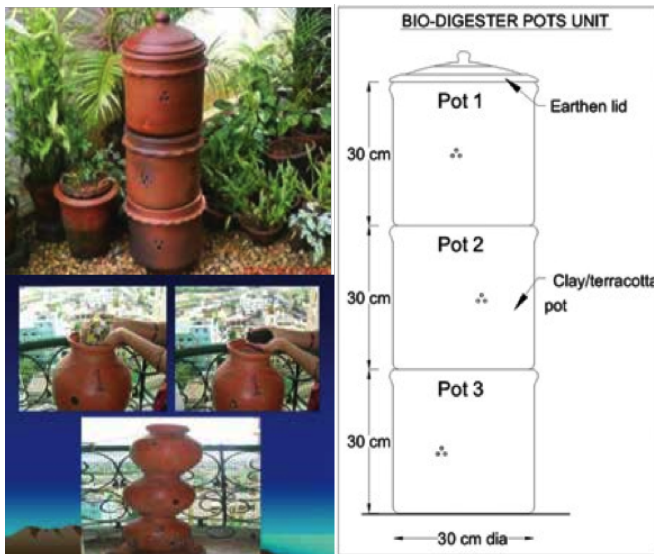

Tri Pot Composting

USER'S FEEDBACK

Name of the unit: Tri Pot Composting

Place of the installation: Palash Co-operative Housing Society Limited, Wakad, Pune

Year of purchase: 2014

Coverage: Individual Household

Biodegradable waste treated per day: 0.5 kg

Compost production: 2.0 kg per pot (each pot will consume up to 8-10 kg of waste)

Processing time: 45 days

Cost of unit: Rs. 3,000 per set

O & M cost: Cost towards cocopeat (Rs. 2/kg-lasts for 10 days) & inoculum (Rs. 45/half a kg-lasts for 6-7 months)

Usage of compost: Completely used for home gardening

Do's & Don'ts: Chop the waste for speedy composting; moisture content should be maintained properly; turn the waste thoroughly at least once in two days for oxygen supply; cover everyday's waste with a layer of soil/compost.

Contact details of the user: Ms. Swati Korde, e-mail: swatikorde@rediffmail.com

4. Bio-Composter

SI No	Description
1.	<p>Bio-composter is used for composting organic kitchen waste generated on daily basis at home level. It consists of three perforated bins mounted one on top of the another. The composting is aided by inoculum – bio-clean (coir pith embedded with microorganisms that catalyzes the composting). Each bin has the capacity to compost organic waste for ten days for a family of 5 members. Thus, one unit (set of 3 bins) can suffice for composting for one month. Composting is completed by 20 days and fully matured by 30 days and can be used for organic farming. By 30th day, one bin can be emptied and ready to be filled again.</p> <p>Operation and maintenance is as follows:</p> <ol style="list-style-type: none"> 1. Lay coconut pith bio-clean inoculum at bottom, two inch thick. 2. Spread the organic waste evenly in the bins as a layer (Gravy and liquid items should be omitted or dried before filling). 3. Cover waste with a layer of bio-clean again (thickness of 1 to 2 inches) 4. Continue the process until the bin is full 5. Once top bin is filled, rotate the bins as top to middle, middle to lower, and lower to top. <p>The organic waste will be converted into compost in twenty days but kept in lower bin till of needs to be emptied and moved to the top.</p>
2.	<p><u>Advantages:</u></p> <ol style="list-style-type: none"> 1. No foul smell 2. Effective and proven method for treating the organic waste. 3. Space required is less can be used for houses with space constraints.
3.	<p><u>Manufactured by:</u> OMEGA ECOTECH PRODUCTS INDIA PVT. LTD, Address: SF.NO. 91/5D, Maha Nagar, Saravananpatty, Coimbatore-641035, Tamil Nadu.</p>
4.	<p><u>Distributed by:</u> GREEN VILLAGE, Reg. No. TVM/TC/1393/2016, Address: P67, Pulekkonem Lane, Sasthamangalam, Thiruvananthapuram, Kerala- 695003, Ph: 91 9895532192, E-mail: greenvillage.green@gmail.com</p>

USER'S FEED BACK

Name of the unit : Bio composter

Place of the installation : Shri Surendran Nair. S

TC 6/1000(6), Sukritham, Vattiyoorkavu P.O.,

Thiruvananthapuram- 695013

Email : ssurendrantvpm@gmail.com

Year of purchase : 2017-18

Place of use : Individual house hold

Biodegradable waste treated : 1.5 kg per day

Processing time : 20-30 days

Cost of unit : Rs. 1800/- per set (3 bins + lids etc)

(Through Thiruvananthapuram Municipal Corporation)

Operation & Maintenance Cost : Rs. 200 per month

(Including costs charges or 10 litre inoculum)

Do's:-

- Chop the waste for speedy composting.
- Moisture content should be maintained / controlled properly.
- Cover every day's waste with a layer of inoculum.

Don'ts:-

- Gravy & liquid organic waste should not be placed in bin unless dried out.

BIO-COMPOSTER

Domestic Source Level Organic Waste Management Unit



Installation of a Bio-composter



Top View



5. Ring Composting

SI No	Description	Unit Cost
1	<p><u>Specification and Size</u></p> <ul style="list-style-type: none"> Ferro-cement ring of internal diameter 0.7m, thickness 2.5cm and height 0.5m placed over a circular Ferro cement base slab of dia 0.75m and thickness 2.5 cm (without fixing to base). The ring to have a 30cm x 30cm opening on the side at the bottom with a Ferro- cement slab cover of the same curved shape which can be removed and refitted back tightly with a locking arrangement for removal of compost when ready. The ring will also have a hole of dia 2.5cm at the bottom for the leachate to flow out. Circular Ferro-cement cover slab of 0.75m diameter and 2.5cm thick with central circular hole of 0.30m diameter to cover the ring. The hole will have a lid cover which can be removed and refitted back for loading the waste into the ring and closing it tightly after loading the waste. Option to provide HDPE sheet 15mm thickness in lieu of Ferro- cement slab at the base can also be given in such case the cost can be reduced by Rs.350/- 	Rs.2500/ set
2	<p><u>Infrastructure Requirements</u></p> <ul style="list-style-type: none"> Two sets of circular Ferro-cement rings resting on circular Ferro cement slabs and covered by a circular Ferro cement lid with provision for loading the waste from the top and removing the Compost from the bottom, when ready. Base layer with cow-dung (5kg) powder. Surgical hand gloves for handling waste and manure. 	
3	<p><u>Operation & Maintenance</u></p> <ul style="list-style-type: none"> First apply a base layer of cow-dung (5kg) powder in the ring. Chop the waste to size less than 5cm before placing in the Ring. Remove the top central lid cover of the ring and drop the waste inside the ring. Spread the waste evenly within the ring. Use first ring for the first 90 days and then use the second ring after the first ring is filled. After 175 days, compost from the first ring can be emptied from the side opening and the ring can be used for further waste feeding. Renew the base layer annually 	

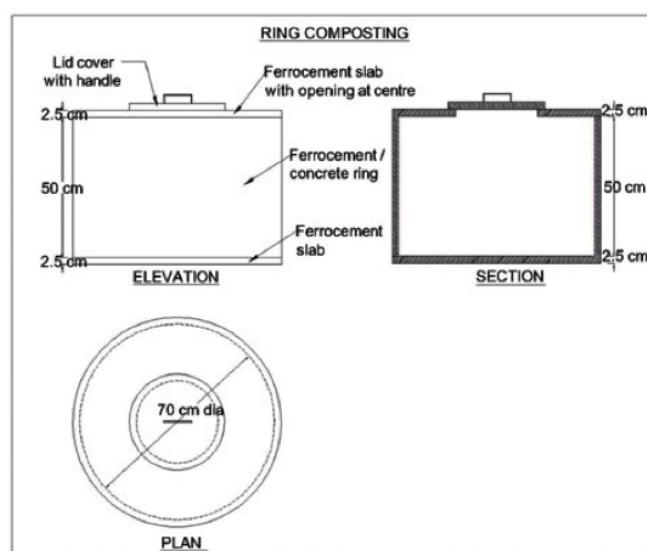

Ring Composting

USER'S FEEDBACK

Name of the unit: Ring Composting

Place of the installation: Vishwam, Mundayode, Mattanur, Kerala

Year of purchase: 2015

Cost of unit: Rs. 120 for 2-rings (given at subsidized cost). The current market price of two rings is Rs. 2,400.

Coverage: Individual Household

Biodegradable waste treated per day: 0.5 – 1 kg

Compost production: 25 kg per ring

Processing time: 6 months after the deposition of last waste

O & M cost: Cost towards lime and cowdung

Usage of compost: Completely used for home gardening

Do's & Don'ts: Chop the waste for speedy composting; turn the waste thoroughly at least once a week for oxygen supply; use cowdung during the start of the process; treatment of citrus fruits should be avoided.

Contact details of the user: Mr. Mukundan, e-mail: mukundank2@gmail.com

6. Kitchen Bin Composting

Sl No	Description	Unit Cost
1	<u>Specification and Size</u> <ul style="list-style-type: none"> • 25 litre plastic bin with lid – 1 Nos. • Plastic grow bags – 3 Nos 	Rs.410/-
2	<u>Infrastructure Requirements</u> <ul style="list-style-type: none"> • Trowel small size • Small fork 	
3	<u>Operation & Maintenance</u> <ul style="list-style-type: none"> • Place the plastic bag inside the bin. • Spread starter material in 1 inch thick layer over the bottom as bio-platform. Either prepared bio- compost or saw dust treated with bio-culture can be used as starter material. Mix saw dust with diluted bio-culture (bio-culture water ratio 1:50) and keep it in a sack bag duly tied. After two days, saw dust mixture becomes hot by the activities of the bacteria. This hot mixture can be used as the starter. • Spread the shredded waste over the starter layer • Spray diluted bio-culture mixture over the waste. After third day, use the fork to mix the contents of old layer and new layer. • Repeat the procedure till the bin is filled. • Tie the grow bag and remove it and store it. • Keep the second grow bag inside the bin and continue the process. • Once the second bag is filled, remove it and store it. Open the first grow bag and remove the contents and start using it again. If the waste quantity is more than 2kg/day increase the number of grow bags to give at least 20 days of storing time for filled grow bag. 	



Kitchen Bin Composting

USER'S FEEDBACK

Place of Installation: Nirvana Espace, Gurgaon

Year of installation: 2014

Tentative Cost: Rs 100-150/- for a bin

Processing Time: 60-75 days

Biodegradable waste treated per day: 0.7-0.8 kg

Compost Production: 7-8 kg per bin

O& M cost: Negligible

Use of Compost: Used for home gardening

Do's & Don'ts: Chop the waste for speedy composting; moisture content should be maintained properly; turn the waste thoroughly at least once in two days for oxygen supply; cover the everyday's waste with a layer of soil/compost.

User Name and Contact No: Ms. Shubha, shubh09@gmail.com

7. Mose Pit Composting

SI No	Description	Unit Cost
1	<u>Specification and Size</u> <ul style="list-style-type: none"> • Pit of size 60cm diameter and depth 1m for a family of 5 members. • Diameter of the pit may go up to 1.5m for institutions • Restrict the depth to 1m in all cases as methanogenic activities get reduced at lower depth. • The bottom of the pit is of oval shape. • The cover slab of size 75cm diameter (for a pit of 60cm diameter) and thickness 7.5cm. • PVC pipe of 100mm dia for domestic type and can be upto 200mm diameter for bigger size pits. • Cover the pit with the cover slab and spread earth over the slab. • Only the pipe will be visible above the ground. • This method is not suitable where earth strata is loose. 	Rs.900/- (For family of five members)
2	<u>Infrastructure Requirements</u> <ul style="list-style-type: none"> • Circular pits of required diameter and depth 1m in a convenient location – 2 Nos • Circular/ rectangular slabs to fully cover the pit, with PVC pipe of required diameter, 50cm long, vertically placed centrally on the cover slabs - 2 sets. • PVC caps to close opening of the pipe – 2 Nos 	
3	<u>Operation & Maintenance</u> <ul style="list-style-type: none"> • Ensure bacterial seeding before putting the waste into the pit by sprinkling cow-dung/ decomposed waste into the pit. • Drop the shredded bio-waste into the pit through the pipe opening daily and keep the pipe end closed always. • Pouring of warm water of 35° to 45°C temperatures once in a week will accelerate the decomposing. • Occasionally pouring of cow-dung mixture or any bacterial seed into the pit will be helpful • Keep using the pits alternately for six months each. 	

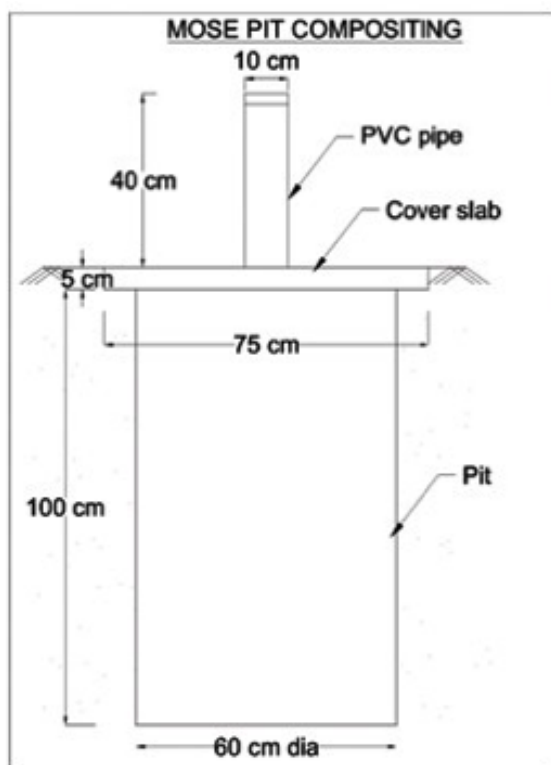

Mose Pit Composting

USER'S FEEDBACK

Name of the unit: Mose pit composting
 Place of the installation: Pungalukadu Gram Panchayat, Kollam District, Kerala
 Year of purchase: 2014
 Capital cost: Rs. 1,000 per set
 Coverage: Individual household
 Biodegradable waste treated per day: ~ 0.7 kg
 Compost production: less than 3 kg/unit/cycle (capacity of the unit is around 10kg)
 Processing Time: 30 – 45 days
 O & M cost: Cost spent towards cowdung powder.
 Usage of compost: Completely used for gardening purpose
 Do's & Don'ts: Level of water table of the area is to be considered before selecting the capacity of the composter.
 Contact details of the user: Mr. Ameersha, e-mail: ameeracl@gmail.com

8. Blue HDPE Compost Digester

Provider	Shudh Labh
Method	Aerobic
Capacity	6 kg per day / 10 households
Ideal Community Size	5-50 households or small offices
Add-on Supplies	Bioclean Cocopeat
Infrastructure	100 sq. ft. covered space
Processing Time	6 weeks
Investment Cost	Rs. 8,000 per digester / Rs. 800 per HH
Running Cost	Rs. 500 per month / Rs. 50 per month per HH

<p>Operation & Maintenance</p>	<ul style="list-style-type: none"> Initially layering needs to be done inside bin by placing a 5kg coco peat block, 1 or 2 buckets of Browns (Dry Leaves) or ~ 2kg of well done compost. Layer about 6-8Kgs of Kitchen waste – Ensure this is well segregated waste and is evenly layered. Add about 100-200gms of Bioclean powder (coco peat with composting Microbes). After the above 3 steps, on daily basis add a layer of Kitchen waste (6-8Kgs) and Bioclean Powder (100-200gms) and some browns. Each of this should be layered well. Once a week, soak a handful of Neem powder in water and sprinkle this water into the digester. This will help reduce flies, insects and odor. Cow dung, Cow urine, panchagavya or sour curd if available, can be added to increase the natural microbial activity and reduce foul smell and insects. 8-10 weeks is the processing time and the first batch of manure will be ready. Spread the extracted compost on the plastic sheet and allow it to dry for a day or two in shade. After the compost is dry, sieve the compost to produce fine manure and store this fine sieved manure in a dry place away from direct sunlight. The left over compost after sieving can be added back to the digester. From the second batch the compost can be extracted every 2nd / alternate week.
<p>Contact</p>	<p>Email: info@sudh-labh.in, ramanan@sudh-labh.in Phone: +91 70907 98830 (Mr. Nikhin) Website: http://www.shudh-labh.com</p>



Blue HDPE Compost Digester

USER'S FEEDBACK

Name of the unit: Shudhlabh HDPE Blue Drum digesters

Place of the installation: Singapore Gardens Layout, Kanakapura Road, Bengaluru

Year of purchase: 2014

Capital cost: Rs. 4,00,000 including infrastructure

Coverage: 120 households

Biodegradable waste treated per day: 50-60 kg

Compost production per day: 10-15 kg

O & M cost: Cost spent towards cocopeat.

Usage of compost: Completely used for gardening purpose within the campus

Do's & Don'ts: The operation and maintenance described should be strictly followed.

Contact details of the user: Mr. Sreenath, e-mail: sreenath.ab@gmail.com

9. Eco Pots	
Provider	We farm techs
Capacity	~ 3.5 kg per pot
Ideal Community Size	Most suitable for individual households and flats
Add-on Supplies	None
Infrastructure	20-40 sq. ft. open space with access to sunlight
Processing Time	3 weeks for waste to compost
Investment Cost	Rs. 4000 for 20 pots for single household
Running Cost	Cost of plants/seeds
Operation & maintenance	<ul style="list-style-type: none"> • Each pot is of 12 litres (i.e., 7L for waste & 5L for the plant). • Pot has a groove for the separator and a stem support. • Separator with holes on it is fitted in the pot to divide the plant and waste (compost) chamber. • Fill plant part with garden soil and bury the plant/seed of the required vegetable/flower plant etc. • Fill 1-inch of soil in the bottom of the waste part. Afterwards fill the organic waste onto to it. • Cover the waste with 1 inch of soil at the end of the day. • Repeat the procedure until the waste part is completely filled with waste-soil composition. • Water the plant part alone whenever it is needed. • The waste in the waste part will be decomposed by the bacteria and other microorganisms. Roots of the plant in the plant part will pass through holes in separator, take up the nutrients from the compost for its growth and bear the vegetables/flowers etc. • A series of pots can create sequential composting for many months of use. • It is recommended to have at least 20 pots per family for treating their waste. However, the number of pots may vary according to need.
Contact	Mr. Vijayan, We Farm Techs, 19, 1st Parthasarathy Nagar, Chennai, Mobile: +91 9444295676, Email : vijayanrd@gmail.com, Website: www.ecopots.in, www.neuecotechs.com

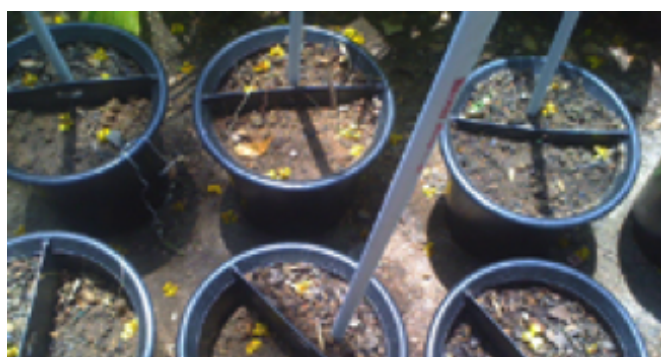

USER'S FEEDBACK

Name of the unit: Ecopots

Place of the installation: Idayarpalayam, Coimbatore, Tamil Nadu

Year of purchase: 2016

Cost of unit: Rs. 2,000 for 10 pots

Coverage: Individual Household

Biodegradable waste treated per day: ~ 0.5 kg

No. of days taken for each pot to fill: 3 days

O & M cost: Cost towards purchasing seeds/plants

Do's & Don'ts: Chop the waste; moisture content should be maintained properly.

Contact details of the user: Mr. Venugopal,
e-mail: mychoicesvg@gmail.com

10. Drum Composting	
Provider	Muskan Jyoti Samiti
Capacity	For individual house - 2 Drums of 50 L capacity each For 15 families – 3 drums of 200 L capacity each
Ideal Community Size	Most suitable for individual households, temples, vegetable & fruit markets, small, medium & big colonies, apartments etc.
Add-on Supplies	None
Infrastructure	Space for keeping the drums
Processing Time	15-25 days
Investment Cost	Rs. 1500/drum
Running Cost	Rs. 50/250 ml culture which is sufficient for treating 80-100 kg of waste.
Operation & maintenance	<ul style="list-style-type: none"> • Take a plastic drum of 200 litres capacity (for individual house 2 drums of 50 litres) • A tap is fitted at the bottom of tank for the collection of leachate. • Place the drum on a base of adequate height, so that a 5 L jar/plastic container can be kept below it, under the tap. • Prepare the liquid culture by mixing adequate amount of culture in water. For treating 80-100 kg of waste mix 250 ml of culture in 3 litres of water (i.e. final mix will be 3.25 L) • Collect the segregated waste in plastic net bag of 25 kg capacity and tie a knot by plastic rope of 15 cm when it gets filled. • Keep the plastic net bags in the drum • Mix the segregated waste with the culture solution inside the drum by wearing gloves. • After mixing, put some bricks/ peedha inside the drum in such a way that the bags carrying the waste do not block the tap. • Continue the above processes until the drum gets filled. • Pour the remaining leftover solution of the container into the drum from the top and close the lid of the drum. • Place a 5 L jar/plastic can below the tap. • Keep the tap open and collect all the leachate coming out of the tap. • Till third day, pour back the liquid collected into the drum. • Open the drum on the third day, observe whether degradation is uniform or not. • If not uniform, then add more liquid solution to it by mixing 250ml culture with 3litres of water for 80-100 kg of waste. • Whenever process starts to smell then add some more culture (mixed with water) to it. • On the 22nd day, take out all the net bags from the drum and spread the contents of the net bag on the ground to dry. • After drying the solid waste for 2 days, sieve it and thus the compost is ready. • The liquid left inside the drum is also a manure, so collect it and use it after proper dilution.
Contact	Mr. Meva Lal, Chaudhary Purwa, Old Kechwa Farm, Madiyawa Village, Kursi Road, Lucknow-226021, Mob. 9415410043, e-mail: muskanjyoti1994@gmail. com, Website: http://www.muskanjyoti.org



Drum Composting

USER'S FEEDBACK

Name of the unit: Drum Composting
 Place of the installation: Durkapur Khalasi Line, Saharanpur, Uttar Pradesh
 Year of purchase: 2012
 Cost of unit: Rs. 400-500 for 50 L unit
 Biodegradable waste treated per day: 0.6– 0.7 kg
 Manure production: Compost – 2-3 kg/50 days cycle (30 days for depositing waste and 20 days processing time) & Liquid Manure – 5 L/50 days cycle
 Processing time: 20 days after the addition of last batch of waste
 Usage of manure: Used in own garden
 Selling price of manure by others in the locality: Compost – Rs. 4/kg, Liquid Manure – Rs. 30/L
 O & M cost: Approx. Rs. 150/90 days towards culture
 Do's & Don'ts: Chop the waste for speedy composting; do not put oily articles and food stuff.
 Contact details of the user: Mr. Mayank Pandey, e-mail: mjsre.sre60@gmail.com

11. Rotary drum composting (Small)

Method	Aerobic
Processing Time	15-20
Capacity	A batch Rotary drum of 250 L capacity is used for batch composting of household organic waste
Machine Description	<ul style="list-style-type: none"> • The inner side of the drum is covered with anti-corrosive coating. • The drum is mounted on four rubber rollers and attached to metal stand. • The drum is rotated manually. • In order to provide the appropriate mixing of wastes, 40mm long angles are welded longitudinally inside the drum. • In addition, two adjacent holes are made on top of the drum to drain excess water.
Operation & Maintenance	<ul style="list-style-type: none"> • Waste mixture is shredded to 1 cm in order to provide better aeration and moisture control. • Once a day clockwise turning was carried out manually by handle, which ensures proper mixing and aeration. • Thereafter, aerobic condition is maintained by opening half side doors. • Two to three rotations at a time are made to ensure that the material on the top portion moved to the central portion, where it is subjected to higher temperature. • Primary stabilized compost is achieved within 15-20 days.

12. Composting Basket/Bin

Method	Aerobic
Processing Time	45 -60 days
Cost of the unit	Rs. 500 to Rs. 800
Operation & maintenance	<ul style="list-style-type: none"> • Shredded biodegradable waste is put into the basket. • The basket is kept at a well-ventilated elevated place. • The waste is stirred with a rod to accelerate the decomposition process. • Manure will be generated after 45 to 60 days.



USER'S FEEDBACK

Name of the unit: Composting Basket/Bin

Place of the installation: Vishwa Apartments, Vashi, Navi Mumbai

Year of purchase: 2017

Coverage: Individual Household

Cost of the unit: Rs. 600/basket

Capacity of the unit: 12-15 kg

Biodegradable waste treated per day: 0.5 kg

Compost production: ~ 7 kg per cycle

O & M cost: Negligible

Processing time: 30 - 45 days

Usage of compost: Used in home garden

Do's & Don'ts: Stir the waste at least once a day, grind/shred the larger waste into smaller pieces, cover the every day's waste with newspaper, keep the basket in elevated slightly position from the ground for proper ventilation, whenever smell arises add cocopeat, sawdust or dry leaves and mix it.

Contact details of the user: Ms. Shivani Naik, e-mail: shivani.naik24@gmail.com



Composting Basket/Bin

2.2: Waste to compost systems for medium sized communities, apartments, RWAs - for 11 – 300 Households; medium sized offices, medium hotels, resorts, medium schools, canteens, marriage halls

1. Vermi Composting
2. Portable Household Bio Bin
3. Aerobic Bin Composting
4. Centralised Masonry Biotank Composting
5. Organic Waste Composting Machine
6. Byobin
7. Orbin
8. Solar Composter
9. Aaga
10. Bokashi
11. Plastic crates
12. Steel Mesh Composter
13. FRP Aerobic Digester
14. Drum Composting
15. Wet Waste Composter

1. Vermi Composting

SI No	Description	Unit Cost
1	<p>Specification and Size – Anyone below:</p> <p>a) Two numbers of broad mouth PVC basins of 25 litre capacity each or one PVC basin of 50 litre capacity with a partition at the centre, minimum weight of the combined unit be 2.5kg or</p> <p>b) Two numbers of broad mouth fibre basin 25 litre capacity each or one fibre basin of 50 litre capacity with a partition at the centre (minimum thickness of the fibre body 3mm) or</p> <p>c) Mud pots country burnt two numbers capacity 25 litres each or</p> <p>d) Terracotta jars with lids two numbers, 25 litre capacity each</p>	<p>Rs.1200/-</p> <p>Rs.1400/-</p> <p>Rs.950/-</p> <p>Rs.980/-</p>
2	<p>Infrastructure Requirements</p> <ul style="list-style-type: none"> • Base layer with coconut fibre/gravel/sand with cow-dung (5kg) powder. • Wire-mesh lid covers. • 200 earthworms in each tank. • Holes at the bottom of the basin/pot/tank to drain leachate/vermi wash to a vessel if kept below. • Arrangements for protecting the basin/pot/tank from rats, ants, etc. • Thick wet cloth or wet sack piece for covering the waste. • Surgical hand gloves for handling waste & manure. • Vermi wash collection system is optional. 	
3	<p>Operation & Maintenance</p> <ul style="list-style-type: none"> • Chop the waste to size less than 5cm before placing in the Basin/ pot/ tank. • Thickness of waste layer should not exceed 15 cm. • Use one basin/ pot/ tank for the first 15 days and then use the second basin/ pot/ tank after filling the first. • Sprinkle cow-dung powder along with waste. • Protect the vermi basins/ pots/ tanks from rats, ants and other pests. • Keep the waste covered with wet sack or cloth. • Sprinkle water over the cover sack/cloth to maintain moisture of 50-55%. • Avoid over sprinkling of water and stagnation of liquid at the bottom of the basin. • Vermi Basin/pot/tank should not be exposed to direct sun light or rainfall. • Prevent introduction of excessive hot, sour and oily substances and also bones, meat & fibre materials. • For removing the vermi compost, expose the basin/pot/tank with contents in shaded sunlight for 2-4 hours and remove the compost from the top and use the basin/pot/tank with earthworms for further composting of bio-wastes. • Compost taken out should not be dried under sunlight. • Renew the base layer annually. • Collect wash out from the basin in the final stages of composting for vermi wash. 	



Vermi Composting

USER'S FEEDBACK

Name of the technique: Vermi Composting

Place of the installation: Vishveshapuram, Pammal Municipality, Tamil Nadu

Year of commencement: 2005

No. of pits: 72 nos.

Cost of unit: Rs. 10 Lakh

Biodegradable waste treated per day: 2.5-3 tonnes

Compost production per day: 800 kg – 1 tonne

Processing time: 45 days

Usage of Compost: Given to farmers and local nurseries & gardens at free of cost

Market value of the compost: Rs.5,000-7,000/MT (information by Sikri Farms, Haryana)

O&M cost: Negligible

Do's & Don'ts: Maintenance of temperature and moisture content is essential for the survival of earthworms.

Contact details of the user: Pammal Municipality, Tamil Nadu, e-mail: commr.pammal@tn.gov.in

2. Portable Household Bio Bin

SI No	Description	Unit Cost
1	<u>Specification and Size</u> <ul style="list-style-type: none"> • Around 40-45 Kg of kitchen waste can be composted in the system. Dimension of the bin is length 180 cm, 75 cm of width & height respectively. (1cu m = 1000 litres) • Biobin – 2 Nos 	Rs.62,200/- (For set of 2 bins)
2	<u>Infrastructure Requirements</u> <ul style="list-style-type: none"> • Sprayer: A Sprayer of one litre capacity to spray dung water. • Steel fork: 1 large and 1 small. • Steel pan: A steel pan of 40 cm diameter to draw out the compost. • A 2 m flex sheet to dry out the compost. • A steel cutting knife. • One set of bio bin is required for 40 families, each generating 1 kg biodegradable waste per day (family size 4-5 persons). • The size/number of biobins can be increased depending upon the respective increase in the families or the members. • A bin can be easily fabricated by joining rectangular fiber sheets, structurally strong. • Air holes must be provided on the sides of the bin for the proper air circulation/ventilation. 	
3	<u>Operation & Maintenance</u> <ul style="list-style-type: none"> • The segregated organic waste from the source is cut or chopped into small pieces (max. 5 cm). • These chopped pieces are then put in the bin (avoid plastics). • Occasionally spray dung water. • Repeat the process daily. • One bin may fill up in 15 days. After 15 days, cover the first bin with a lid and start filling in second bin. • When the second bin is full, the waste in the first bin would have become compost. • This compost has to be dried on the terrace under-shade for a day to get it dried and can be used as fertilizer for plants. 	



Portable Household Bio Bin

USER'S FEEDBACK

Name of the unit: Portable Household Bio Bin

Place of the installation: Skyline Topaz Apartments, Kochi

Year of purchase: 2008

Coverage: 96 Households

Biodegradable waste treated per day: ~ 50 kg

Compost production: 60-75 kg from each bin (each pot will accommodate about 750 kg of waste)

Processing time: 15 days after adding the last waste

Cost of unit: Rs. 75,000 for two bins

O & M cost: Rs. 470/month towards culture

Usage of compost: Used for home gardening and the balance given to CREDAI for free of cost

Do's & Don'ts: Chop the waste for speedy composting; stir the waste thoroughly at least once in two days for oxygen supply; spray the bio-culture at the end of each day after adding the waste.

Contact details of the user: Ms. Magi George, e-mail: skylinetopaz@hotmail.com

3. Aerobic Bin Composting

Sl. No.	Description
1.	The composting unit includes a box like structure with Ferro cement floor. Layers of cow dung, carbon source and waste materials are subjected to composting in presence of oxygen. The temperature rises rapidly in the waste to almost 70°C, the peak temperature killing pathogens. An efficient aerobic compost bin does not emit foul ammonia like smell.
2.	<p>Technical Aspects</p> <p>Aerobic cluster composting unit consists of two units. Each unit is a 120cm x 120cm x 120cm ferro cement bin with airspace and grooves utilizing bacteria consortium from cow dung and carbon source from dry leaves and paper bits with a roof to prevent rain water. 6" layer of fresh cow dung as the first layer with 6" layer of dried leaves provide the carbon source for the bacteria to flourish, above that another six inch layer waste is laid which gets converted into compost.</p> <p>The core temperature built up in this layering is 70 - 75°C which prevents the breeding of flies and parasites. Moreover due to aerobic functioning no putrid smell is present. About 1000kg waste can be managed in a bin. It can give compost with carbon nitrogen ratio 20 - 30% after 90 days.</p>
3.	<p>Operation & Maintenance</p> <ul style="list-style-type: none"> • A 6 inch layer of fresh cow dung is laid as the first layer. • A 6 inch layer of dried leaves is laid on top of the cow dung layer. • Above that 6 inch layer waste is added and inoculum containing enzymes made from cow dung is sprayed, this hastens composting. • Alternate, 6 inch layers of dried leaves and waste sprayed with inoculum is repeated till the bin is filled. • Once the first bin is filled, start using the second bin. By the time the second bin is filled, the contents in the first bin will turn into compost.
4.	<p>Unit Cost</p> <p>A unit with two aerobic bins will cost Rs.41,000. Providing enclosed rain shed with provision for drainage and soak pit for leachate, ramp for trolley etc. will cost Rs 1,40,000/-.</p>

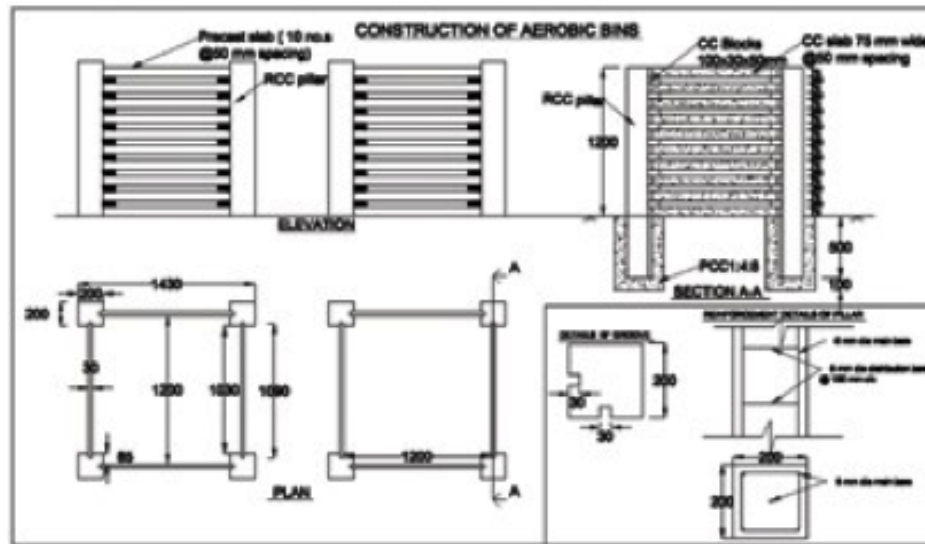

Plan, Section and Elevation of Aerobic Bin Composting



Aerobic Bin Composting

USER'S FEEDBACK

Name of the unit: Aerobic Bin Composting

Place of the installation: Chala, Municipal Corporation of Thiruvanthapuram, Kerala

Year of commissioning: 2015

Cost of unit: Rs. 1.5 Lakh/2 bins

Coverage: 860 Households

Biodegradable waste treated: 1 tonne/bin

Compost production: 400-500 kg/bin/cycle

Processing time: 45-60 days after the addition of last waste

O & M cost: Rs. 100/month

Usage of compost: Given to farmers and agricultural department at free of cost

Do's & Don'ts: As per the operation & maintenance procedure as above.

Contact details of the user: Mr. Anoop Roy, Health Inspector, Project Secretariat, Corporation of Thiruvanthapuram, e-mail: anooproy007@gmail.com

4. Centralised Masonry Biotank Composting

SI No	Description
1	<p><u>Specification and Size</u></p> <ul style="list-style-type: none"> For an apartment of 40 units, at least 2 nos. of tanks each of capacity 2 m × 1.2 m × 1 m (2.40 cu m) are required. It is recommended to build the tank at the central part of the Apartment with RR masonry foundation and a brick wall.
2	<p><u>Infrastructure Requirements</u></p> <ul style="list-style-type: none"> A temporary roofing to be provided for protection from rains. A net to avoid birds/insects attack. A dung mixture comprising of cow dung, Jaggery, condiments, yeast and fibre.
3	<p><u>Operation & Maintenance</u></p> <ul style="list-style-type: none"> Put the bio degradable wastes in the tank. Spray the organic mixture of cow dung, Jaggery, condiments, yeast and fibre above the waste. Once the first tank is full, use the second tank and then the third tank. The leachate from the tank can be collected through a tap provided at the bottom of the tank and can be used as manure for plants or can be drained to Septic tank/Soak pit or sewer Once the third tank is filled, the compost from tank 1 is emptied and it can be used again and the entire process gets repeated.

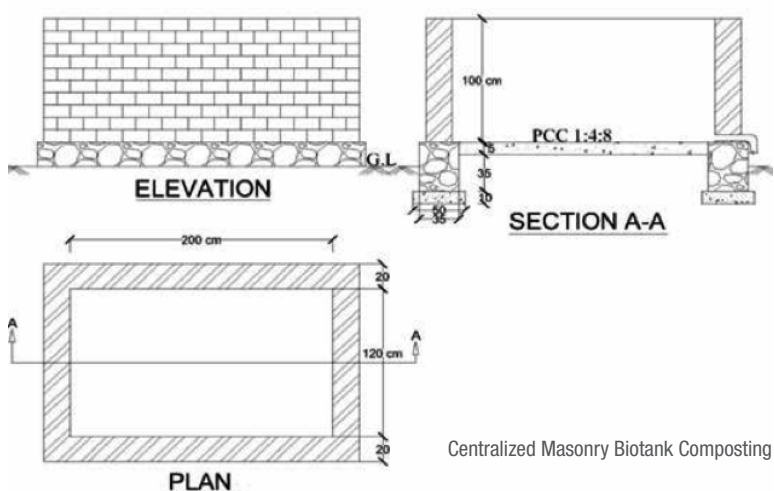

USER'S FEEDBACK

Name of the unit: Centralised Masonry Biotank Composting

Place of the installation: Pookollai, Tiruchirappalli City Municipal Corporation, Tamil Nadu

Year of commissioning: 2016

Coverage: 5482 Households + 2 bulk waste generators

Biodegradable waste treated per day: 5 MT

Total no. of pits: 16 nos.

Compost production: 4.28 MT/month

Processing time: 45 days

Cost of plant: Rs. 68.00 Lakhs

O & M cost: Rs. 3.54 Lakh/month

Usage of compost: Given freely to the farmers

Do's & Don'ts: Shred the waste into smaller pieces for speedy composting; moisture content should be maintained properly; stir the waste thoroughly at least once in two days for oxygen supply.

Contact details of the user: Tiruchirappalli City Municipal Corporation, e-mail: commr.trichy@tn.gov.in

5. Organic Waste Composting Machine

SI No	Description
1	<p><u>Specification and Size</u></p> <ul style="list-style-type: none"> Certain shredding machines like bio-waste converting machines which can shred 10, 25, 50, 125, 150 Kg of wastes at a time are available in the market.
2	<p><u>Infrastructure Requirements</u></p> <ul style="list-style-type: none"> Plastic bags of capacity 20 Kg. Racks for the safe keeping of the bags containing partially processed waste. Room of dimension 3 m × 4 m with proper ventilation for installing machinery and safe storage of racks and baskets is required. An organic solution, power connection of 4 - 10 KW and water connection are required. Investment cost – Rs. 5 Lakh and above, as per the capacity required.
3	<p><u>Operation & Maintenance</u></p> <ul style="list-style-type: none"> Mix a little cow dung slurry or any other rapid composting material with suggested quantity of segregated waste. Put this mixture in the machine and run the machine for 15 minutes. Transfer the partially composted shredded waste to basket and store in the rack. The moisture content should not be less than 40%. In 15 days, waste will become compost.
4	<p><u>Vendors</u></p> <p>1. Excel Industries Limited, Mumbai Email:owc@excelind.com, Tel.: +91-22-66464342 Website : http://www.excelind.co.in/Excel_ENBT/index.html</p> <p>2. Vennar, Bengaluru Email: vennar10@gmail.com Phone: +91 9844011329 (Narendra Babu) Website: http://www.Vennar.in</p>



Organic Waste Composting Machine

USER'S FEEDBACK

Name of the unit: Organic Waste Composting Machine

Place of the installation: GPRA Complex, New Motibagh, New Delhi

Year of purchase: 2013

Cost of unit: Rs. 40 Lakh including infrastructure (for processing 1.5 tonnes/day)

Coverage: 498 flats/bungalows

Biodegradable waste treated per day: 800 kg

Compost production per day: 200 kg

O & M cost: Rs.25,000/month for the purchase of inoculum and others

Usage of compost: Sold to NBCC (India) Limited

Selling price of the compost: Rs. 5/kg

Do's & Don'ts: Same as operation and maintenance procedure, above

Contact details of the user: Mr. Rajesh Mittal,
 Director, Green Planet Waste Management Pvt. Ltd.
 e-mail: info@gpwm.in, rajesh.mittal@gpwm.in

6. Byobin	
Provider	Pelican Biotech
Method	Aerobic
Capacity	300L to 600L
Ideal Community Size	50-300 households
Add-on Supplies	Inoculum
Infrastructure	Can be kept outside, but rain protection required.
Processing Time	45 days
Investment Cost	Rs. 1000 per household
Running Cost	Rs. 50 per month per HH
Operation & Maintenance	<ul style="list-style-type: none"> • Each Byobin has 300- 600L capacity. It can accommodate maximum 15Kg waste per day. • The bins work in pairs. • In first month 1st bin will be used. • 4-5 inches (~20Kg) of wet waste is sandwiched between 1 inch layer of composorb (inoculum powder) in the 1st bin till the bin is filled up. • A layer of dry leaves over wet waste will reduce maggots and moisture content in the compost • Once the 1st bin is filled, it is left for composting while the 2nd bin is started. • Compost can be retrieved little by little from the top from the 1st bin after 15 days after the last addition to the bins. • The leachate collects in the bottom tank below. • Aerating holes below the net allows cold air to flow in, which provides the required aerobic environment for the composting mass. • The net also provides separation between the leach collection tank and digester maintaining dry compost.
Contact	Email: contact@pelicanbiotech.com , tvvenkat2000@yahoo.com Phone: +91 7204057502, 9447365542 Website: www.pelicanbiotech.com

USER'S FEEDBACK

Name of the unit: Byobin

Place of the installation: Purva Panorama Apartment, Bannerghatta Main Road, Bengaluru

Cost of unit: Rs. 8 Lakh for 400 kg capacity

Year of purchase: 2014

Coverage: 650 flats

Biodegradable waste treated per day: 250-300 kg

Compost production: 1000-1200 kg per Month (~ 40 kg/day)

O & M cost: 15,000/Month towards the chemical @ rate of Rs. 3000/bag of 10 kg.

Usage of compost & brew: Completely used for gardening purpose within the campus and distributed to the residents free of cost (earlier sold to the residents at Rs.15/kg).

Do's & Don'ts: Moisture content should be maintained properly; do not store the compost in air tight containers; only segregated organic waste is to be processed.

Contact details of the user: Mr. Palani, e-mail: ccppaca@gmail.com



Byobin

7. Orbin	
Provider	ORBIN
Method	Aerobic
Capacity	20 Kg and below
Ideal Community Size	20 Households
Add-on Supplies	Bioclean Cocopeat
Infrastructure size	2ft x 2ft
Processing Time	6 weeks
Investment Cost	Rs. 15,000 per Bin
Running Cost	Depends on the quantity of waste
Operation & maintenance	<ul style="list-style-type: none"> • Segregated waste is added from the top of the unit. • Every time organic waste is added to the unit, sprinkle a thick layer of enzyme powder on it, covering it. • This is simple method of sandwiching the waste between two layers of enzymes (Naturally occurring microbes in a cocopeat based medium). • This enzyme creates air pockets, which allows aerobic composting and no turning of waste is required. • Microbes break the waste, releasing the moisture. This is collected at the bottom most section of the unit, in the form of nutrient liquid. • After 30-40 days, the compost can be harvested from the lower section of ORBIN. An opening for this is provided at the bottom.
Contact	Email: anjana@orbin.in Phone: +91 7259404888 Website: www.orbin.in



Orbin

USER'S FEEDBACK

Name of the unit: Orbin

Place of the installation: Emerald Green, Sector 52, Gurgaon

Year of purchase: 2016

Cost of unit: Rs. 15,000/- per unit

Coverage: Individual Household

Biodegradable waste treated per day: ~ 1 kg (i.e., 30 kg/month)

Compost production: 4 - 5 kg/month

O & M cost: Cost towards purchase of 3 bioculums/month @ Rs. 110/bioculum of 700 gm and cost towards buying cocopeat

Usage of compost: Used in own home garden and distributing to neighbours

Do's & Don'ts: moisture content should be maintained properly; put only the segregated organic waste in the system; non-veg. food items should be avoided.

Contact details of the user: Mr. Amit Chaudhary, e-mail: amitvc@gmail.com

8. Solar Composter

Provider	Shree Skanda Solar Systems
Method	Aerobic
Capacity	25 -300 kg per day
Ideal Community Size	30-250 households
Add-on Supplies	Saw dust/ Cocopeat
Infrastructure size	4" X 4"
Processing Time	4 to 5 weeks
Investment Cost	Rs. 1.75 Lakh per digester / 30 households
Running Cost	Rs. 1000 per month / 30 households

Operation & maintenance	<ul style="list-style-type: none"> • Solar Compost Cooker is an aerobic composting device. It utilizes solar heating and solar chimney ventilation principles to speed up composting. • Solar Compost Cooker is designed as a three (3) chamber system. A glass pyramid on the top acts as solar heat collector with an opening to drop wet waste. • Operation: • Mix water & handful of saw dust proportionate to the kitchen wet waste and deposit the mixture through the pyramid door. • Chamber One (Shredder/Mixing) - Drop wet waste every day and turn the handle to mix the waste. Continue to add for about four (4) weeks or longer until it fills the chamber. Pull the separator sheet to drop the mixture to chamber two. Put the separator sheet back and begin adding a new batch of wet waste in the first chamber. • Chamber Two (DIGESTER) - Here, the mixture fully composts for an additional four weeks. • Chamber Three (MATURED) - Finished compost is dried. • A Leachate collection chamber is provided at the bottom to harvest Leachate.
Contact	Email: ysnagendra7@gmail.com Phone: +91 9886197121



Solar Composter

USER'S FEEDBACK

Name of the unit: Solar Composter

Place of the installation: HRBR 1st Block, Kalyan Nagar, Bengaluru – 560043

Year of purchase: 2016

Cost of unit: Rs. 16,000 inclusive of local transportation

Coverage: Single household

Biodegradable waste treated: 15-22.5 kg/month

Compost production per day: 3-5 kg/month

O & M cost: Rs.300/month for the purchase of remix powder, microbes, and neem powder

Usage of compost: Used for terrace gardening

Do's & Don'ts: Proper maintenance of moisture content; add organic neem oil cake powder in small quantities to controls flies and maggots.

Contact details of the user: Mr. Anand, e-mail: va.anand1023@gmail.com

9. Aaga	
Provider	Daily Dump
Method	Aerobic
Capacity	18 kg per day / 25 households
Ideal Community Size	25-200 households
Add-on Supplies	Remix powder
Infrastructure	40 sq. ft. covered space
Processing Time	4 weeks
Investment Cost	Rs. 75,000 per pair / Rs. 3,000 per HH
Running Cost	Rs. 1,000 per month / Rs. 40 per month per HH
Operation & maintenance	<ul style="list-style-type: none"> • Collect segregated biodegradable waste from each home into common bucket. • Mix the Remix Powder into the collected waste buckets. • Add kitchen waste in Aaga 1 . • Add Remix Powder on top of the waste daily. • Once Aaga 1 is full, close it and stop adding waste. • Start filling the second Aaga. • Once Aaga 2 is full, close it and stop adding waste. • By then the compost is ready in Aaga 1, harvest and use the bin again.
Contact	Email: hello@dailydump.org Phone: +91 99164 26661 Website: http://dailydump.org



Aaga

USER'S FEEDBACK

Name of the unit: Aaga

Place of the installation: Salarpuria Serenity, HSR Layout Sector 7, Bangalore

Year of purchase: 2014

Cost of unit: Rs. 65,000/set (Figures provided by Ms. Swati Korde, Pune)

Coverage: 125 Households

Biodegradable waste treated per day: ~ 60 kg

Compost production: 500 kg/15 days

O & M cost: Rs. 12,000-14,000/Month

Usage of compost: Completely used for gardening purpose within the campus

Do's & Don't's: Chop the waste for speedy composting, moisture content should be maintained properly, cocopeat, which is used for daily cover, should be well dried.

Market price of the compost: Rs. 7-10/kg (Figures provided by Ms. Swati Korde, Pune)

Contact details of the user: Mr. Vineet Srivastava, e-mail: vineet.personal@gmail.com

10. Bokashi

Provider	Quantum Leaf
Method	Anaerobic
Capacity	20 kg and below
Ideal Community Size	20 HH
Add-on Supplies	Bokashi bran, Cocopeat
Infrastructure	150 sq. ft. covered space
Processing Time	6 weeks
Investment Cost	40,000 -60,000 depending on requirements
Running Cost	2000/- per month
Operation & maintenance	<ul style="list-style-type: none"> To be operated in pair. Add ~ 50ml liquid jaggery to the bottom compartment, sprinkle 1 Tbsp (2 Tbsp for non-veg) for every handful of wet waste in the bin. Compact it using the presser plate each day & close the lid airtight, leaving the plate inside. Extract the brew in to a cup or bottle from the tap. Tilt the bin if needed. Once the bin is full, remove the plate, close the lid and let it sit for pickling for 2 weeks in a dry place at room temp. away from sunlight. Use the second bin to continue filling kitchen waste. After 2 weeks of pickling, extract the pickle and layer it with mature compost (min. 8 kg) in a suitable aerobic container or in a pit. The top & bottom layers being the mature compost. Protect from weather & mix the contents after a week. After min. 2 weeks of Layering, harvest the earthy smelling compost and dry it to moderate moisture and sieve it.
Contact	Email: sales.leaf@quantumleafguru.com Phone: +91 9035274764, Website: www.facebook.com/quantumleafpage



Bokashi Anaerobic Composter

USER'S FEEDBACK

Name of the unit: Bokashi

Place of the installation: Saundariya Nilaya, Thvarekere Main Road, Bengaluru

Year of purchase: 2017

Cost of unit: Rs. 2400 for 2 bins

Coverage: Single household

Biodegradable waste treated per day: 800gm – 1 kg

Compost production: 10-12 kg per bin (25 day's waste can be treated in each bin approx..)

O & M cost: Cost spent towards cocopeat and jaggery. If required Bokashi Bran, which costs Rs. 100/250gm (enough for 2 bins per cycle).

Usage of compost & brew: Completely used for home gardening purpose within the campus

Do's and Don'ts: Same as operation & maintenance procedure above.

Contact details of the user: Ms. Preeti, e-mail: preeti_emma@yahoo.in

11. Plastic crates

Provider	Reap Benefit
Method	Aerobic
Capacity	1 crate = 10 kg organic waste
	110 crates required per 100 HH
Ideal Community Size	50-100 households
Add-on Supplies	Upgrade Cocopeat Inoculant
Infrastructure	200 sq. ft. covered space, Shredder
Processing Time	4 weeks
Investment Cost	Rs. 350 per crate / Rs. 400 per HH
Running Cost	Rs. 75 per month per HH
Operation & maintenance	<ul style="list-style-type: none"> • Segregated food waste is put through the shredder to cut it up uniformly. • Up'Grade is mixed with the shredded food waste in a ratio of 1:3 by volume. • The shredded waste and Up'Grade mixture is left to cure in the plastic crates for 25 days to make compost.
Contact	Email: info@reapbenefit.in Phone: +91-99866 15136 / +91-98863 61805, Website: http://reapbenefit.in

USER'S FEEDBACK

Name of the unit: Plastic crates

Place of the installation: Infosys Campus, Mysore

Year of purchase: 2015

Cost of unit: Rs. 75,000

Biodegradable waste treated per day: ~ 50-60 kg

Compost production: 15-20 kg/day

O & M cost: Rs. 5,500/month towards the upgrade/culture which costs Rs. 11/kg

Usage of compost: Completely used in the nursery within the Infosys campus

Do's & Don'ts: Moisture content should be maintained properly and the upgrade is to be mixed to the waste in the proportion as specified in the operation & maintenance procedure.

Contact details of the user: Mr. Ananth, e-mail: anantha_bondade@infosys.com



Plastic Crates

12. Steel Mesh Composter

Provider	This method devised by Rainbow Drive RWA, Bangalore
Method	Aerobic
Capacity	1 unit = 50 kg per day
Ideal Community Size	200+ households or independent layouts
Add-on Supplies	Sawdust, dry leaves
Infrastructure	500 sq. ft. covered space
Processing Time	6 weeks
Investment Cost	Rs. 2,500 per unit / Rs. 50 per HH
Running Cost	Rs. 2000 per month (per HH almost Nil)
Operation & maintenance	<ul style="list-style-type: none"> • Put together a square-shaped platform using a few cement slabs. • Leave some gap between each slab so that leachate, if any, drips down easily. • Place a steel mesh plate on top of the slabs to prevent entry of rodents from the bottom. • Make a steel mesh ring of 3 ft diameter and 2.5 ft height (open cylinder). • Place this ring on the platform. • Wrap the ring with gunny sack to avoid the contents from spilling out and messing up the surroundings. • This also prevents rodents from digging into the piles. • Collect the segregated kitchen waste. • Sprinkle little bit of saw dust on it to absorb excess moisture. • Spread a thick layer of (at least 8-10 inches) dry leaves at the bottom of the composter. • This absorbs the moisture content seeping down from the top layers. • Add the bio degradable waste and dry leaves to the composter in alternative layers. • The top portion is always filled with dry leaves to ward off fruit flies, odour, mosquitoes and rodents. • Leave the composter for about 15-20 days. • Afterwards remove and lay it for maturing for another 30 days. • After a total of about 45 days, the compost is ready. Sieve it and store it for consumption. • Bigger and not fully composted parts sieved out are once again added to the composter for composting. • Keep the place tidy and ensure that it is airy and covered (to save from sun and rain).
Contact	Email: kpsingh06@gmail.com Phone: +91 98451 77160 Address: Rainbow Drive Layout, opposite Wipro Corporate Office, Sarjapur Road, Bangalore



Steel Mesh Composter

USER'S FEEDBACK

Name of the unit: Steel Mesh Composter

Place of the installation: Rainbow Drive Layout, opposite Wipro Corporate Office, Sarjapur Road, Bangalore

Cost of unit: Rs. 1000 Rs. For 20 Households

Coverage: 250 Households

Biodegradable waste treated per day: ~ 200 kg

Compost production: 30-40 kg/day

Processing time: 45 days

O & M cost: Cost for few bags of sawdust @ Rs. 30/bag for a month

Usage of compost: Used in the garden within the campus and distributed to the residents free of cost

Do's and Don'ts: moisture content is to be maintained properly; the setup should be in a covered but airy place; churning of the waste must be done, once in 15 days.

Contact details of the user: Mr. K.P.Singh,

e-mail: kpsingh06@gmail.com

13. FRP Aerobic Digester

Provider	Shudh Labh
Method	Aerobic
Capacity	40-50 kg per day 80 households
Ideal Community Size	50-500 households
Add-on Supplies	Bioclean Cocopeat
Infrastructure	150 sq. ft. covered space
Processing Time	10 weeks
Investment Cost	Rs. 63,000 per digester
Running Cost	Rs. 4,000 per month / Rs. 50 per month per HH
Operation & maintenance	<ul style="list-style-type: none"> • Initial layering needs to be done by placing a 5kg coco peat block, 1 or 2 buckets of Browns (Dry Leaves), and ~ 2 kg of compost. • Layer about 6-8Kgs of Kitchen waste – Ensure this is well segregated waste and is evenly layered. • Add about 100-200gms of Bioclean powder (cocopeat with composting Microbes). • After the above 3 steps, on daily basis add a layer of Kitchen waste (6-8Kgs) and Bioclean Powder (100-200gms) and some browns. Each of this should be layered well. • Once a week, soak a handful of Neem powder in water and sprinkle this water into the digester. This helps in reducing the flies, insects and odor. • Cow dung, Cow urine, panchagavya or sour curd if available, can be added to increase the natural microbial activity and reduce foul smell and insects. • 8-10 weeks is the processing time and the first batch of manure will be ready. • Spread the extracted compost on the plastic sheet and allow it to dry for a day or two in shade. • After the compost is dry, sieve the compost to produce fine manure and store the fine sieved manure in a dry place away from direct sunlight. • The left over compost after sieving can be added back to the digester. • From the second batch the compost can be extracted every 2nd / alternate week.
Contact	Email: info@sudh-labh.in Phone: +91 9964508833 Website: http://www.sudh-labh.in/index.html



FRP Digester

USER'S FEEDBACK

Name of the unit: Shubhlabh FRP Digester

Place of the installation: Purva Fair Mount Apartmets, Bengaluru

Year of purchase: 2013

Cost of unit: Rs. 1,10,000 including infrastructure

Coverage: 324 flats

Biodegradable waste treated per day: 250 kg

Compost production: 80-100 kg/2 days

Processing time: 45 days

O & M cost: Rs. 275/ 5 kg block of bioculum. 3 blocks per day is being used for treating the waste.

Usage of compost: Mostly used as seed for the system and the balance is being sold

Selling price of the compost: Rs. 15-25/kg

Do's & Don'ts: moisture content is to be maintained properly; base should be firm with concrete so that ground doesn't cave into due to the weight of the digester.

Contact details of the user: Ms. Suba Sendhil, email: subasendhil@yahoo.com

14. Drum Composting

The details on this method have already been given in section “Drum Composting” of Category – 2.1 above. The same may be referred.

15. Wet waste composter

Provider	Shudh Labh
Provider	Gandhiji's Dream
Method	Aerobic
Capacity	50 kg
Infrastructure	Covered space is required
Processing Time	45 days after putting the last layer of waste
Investment Cost	Rs. 700 + tax per bin
Operation & maintenance	<ul style="list-style-type: none"> • Prepare the base for composter by using coir or grass. • Once the bed is made, open the green lid and put all the kitchen waste. • Make sure no water is poured into the bin and make it as dry as possible. • Black soldier fly will enter through the air pipe and will lay its eggs in the nest placed below the vent. • After some time, the worms from these eggs will move upwards to the specially designed center pipe and will try to exit. • Place a cloth or a tin for the collection of this worms. Alternatively, the middle vent pipe can be disconnected, hence their won't be any escape route for the larva and it will once again fall back in the bin itself and die. • Once the bin is full, keep it for minimum 45 days in dry area for maturing. The compost can be collected after 45 days. • Further, the juice generated from the composter due to decomposition of waste can be collected from the bottom outlet pipe and used as liquid fertilizer.
Contact	Email: ghadijsdream@gmail.com Phone: +91 9421249412



Wet waste composter

USER'S FEEDBACK

Name of the unit: Wet waste composter

Place of the installation: Valpoi, Goa

Year of purchase: 2017

Cost of unit: Rs. 700

Coverage: Individual household

Biodegradable waste treated per day: ~ 0.5 kg

Compost production: Liquid: 1 L/day; Solid: Not yet generated

Processing time: 45 days after putting the last layer of waste (as per the instructions of vendor)

O & M cost: Negligible

Usage of compost: Liquid compost is used in own garden

Do's & Don'ts: The composter should be maintained as dry as possible.

Contact details of the user: Mr. Tayed

2.3: Waste to compost systems for Large Communities, Apartments, RWAs, high rise buildings for 301 – 1000 Households; Large Offices, Large Hotels, Large Schools

1. Organic Waste Composting Machine
2. Marigold
3. Soil and Health SWM consultant Aerobic and Anaerobic Composter
4. Large Scale Composting Pits

1. Organic Waste Composting Machine

The details on this method have already been given in section “Organic Waste Composting Machine” of Category – 2.2 above. The same may be referred.

2. Marigold	
Provider	Prudent Ecosystems
Method	Aerobic
Capacity	1kg/day to 100 Kg/day
Ideal Community Size	Individual to 100 households
Add-on Supplies	Dry leaves
Infrastructure	Can be kept in the open
Processing Time	4 weeks
Investment Cost	~2.75 lakhs/100 homes
Running Cost	one worker is required for 2 hours/day
Operation & maintenance	<ul style="list-style-type: none"> • Segregate the waste. • Use garden shears (or Powered Shredder) to chop down anything that is larger than 2 inches. • For every 1 measure (by volume) of wet waste, add about 30% to 50% measure of leaf dust (or cocopeat) to the wet waste in the tub and stir. • Add this mixture into the composter and spread evenly into one layer. • Move to the next composter if excess waste is available than the maximum level of the current composter. • Once all the waste has been added, level the waste and add a thin layer of dry leaf dust on the top to cover it uniformly. • Sprinkle a little water on this top layer of leaf dust. <p>For the older waste (the previous days waste):</p> <ul style="list-style-type: none"> • Start with the most recent bin. • Divide the unit into 4 quarters. • Take one quarter and pull up the waste a little at a time piling it up on the other 3 quarters. • All the waste being pulled up should be exposed to air. • Any lumps found should be broken down (chopped if needed) and spread out. • The bottom of the composter should be scraped with a trowel to expose it clean. • The waste can then be put back into the quarter. • Repeat the above process for all the quarters. • Next scoop out a small portion in the centre so that anything that was left out from all 4 quarters would be scooped out. • Waste should remain wet (damp) but not soggy. It should be a little more than just moist. On sunny days, the amount of water added should be such that till the next service visit (24hrs), the waste being composted should remain at least moist. • On rainy days, to reduce the moisture by sprinkling some leaf dust over the waste. If too wet, then leave the lid open for drying. • The waste needs to be maintained in the composter for a period of 12 days. • After 12 days, the waste is to be emptied out into a cloth bag and left in a damp condition in the shade. • The curing period is a minimum of 20 days, but for ease of operation, it can be 24 days (i.e. two cycles of 12 days). • Unlike traditional composting systems, the Marigold System does not involve the use of additives or microbes.
Contact	Email: latha@prudentecosystems.com Phone: +91 9886003355, Website: www.prudentecosystems.com



Marigold

USER'S FEEDBACK

Name of the unit: Marigold

Place of the installation: Brigade Paramount Apartments, Old Madras Road, Bengaluru

Year of purchase: 2015

Cost of unit: Approx. Rs. 2 Lakh for 8 composters for 80 flats

Coverage: 80 flats

Biodegradable waste treated per day: 50 kg

Compost production per day: ~10 kg

O & M cost: cost towards purchasing cocopeat & dry leaves for mixing

Usage of compost: 50 % is used for gardening purpose within the campus and rest is being sold

Selling price of the compost: Rs. 7-10/kg

Do's & Don'ts: Same as the operation and maintenance procedure, above.

Contact details of the user: Mr. Ravishankar Ayyagari, e-mail: ravidasv@gmail.com

3. Soil and Health Solutions Anaerobic Composter:

Provider	Soil and Health Solutions
Method	Anaerobic
Capacity	20 Kg to 500 Kg
Ideal Community Size	20 HH to 500 HH
Add-on Supplies	Bokashi bran powder, cocopeat
Infrastructure	Required based on wet waste quantity
Processing Time	6 weeks
Investment Cost	2000/- to 3000/- per household
Running Cost	150/- per household/ month
Operation & maintenance	<p>Aerobic:</p> <ul style="list-style-type: none"> • Collect the segregated organic waste. • Add the waste to the unit in alternative layers of bio degradable waste and dry leaves. • Add fresh cow dung, at least once, at the beginning of the composting process. • After 30-45 days, the compost is ready. Sieve it and store it for consumption. • Bigger and not fully composted parts sieved out are once again added to the composter for composting. • Keep the place tidy and ensuring that it is airy and covered (to protect from sun and rain). <p>Anaerobic:</p> <ul style="list-style-type: none"> • Soak 900gm of cocopeat brick in 1.5 L of water for 2-3 hrs in the bin. This expands to 10 L of cocopeat. • Add half of the powdered brick at the bottom of the bin. • Sprinkle a tablespoon of bokashi bran over the cocopeat. • Add approx.. 2kg of waste into the bin evenly. • Sprinkle a tablespoon of bokashi bran over the waste. • Again add approx.. 2kg of waste into the bin evenly. • Follow this process till the bin is full. • Use a press plate to remove the air and to pack the waste tightly. • Follow the above procedures of filling and packing until the bin is full. • Topup the remaining bin with remaining cocopeat and Close the lid air tight.
Contact	www.soilandhealth.in,vasuki.iyengar@gmail.com, Contact : 9845690778



Soil and Health Solutions Aerobic and Anaerobic Composter

USER'S FEEDBACK

Name of the unit: Soil & Health aerobic composter

Place of the installation: Gopalan Grandeur, Hudi Circle, White Field, Bengaluru

Year of purchase: 2015

Cost of the unit: Rs. 4,500 per bin

Biodegradable waste treated per day: ~ 1-2 kg

Compost production per day: ~ 11 kg per cycle of 30 days

O & M cost: Cost spent towards bokashi bran pockets, cocopeat blocks & neem powder

Processing time: 30 days

Usage of compost: Completely used for home gardening

Do's & Don'ts: Do not reduce the ratio of 500 gms of bokashi bran to 900 gms of regular cocopeat per day in one bin; If worms appear, remove the lid, use pressing plate to remove any trapped air and pack with coco-peat on top to the brim and close airtight.

Contact details of the user: Ms. Lakshmi Shankaran, e-mail: laksan_inin@yahoo.com



4. Large Scale Composting Pits

Method	Aerobic
Infrastructure	Kept in covered in enclosure
Processing Time	45 days
Operation & maintenance	<ul style="list-style-type: none"> • The segregated biodegradable waste is shredded and mixed with saw dust & dry leaves in a Shredder cum Blender. • The Shredder cum Blender (powered by a 2HP motor running on 2 Amps power) generates a semi solid homogenous matter or paste which is finally put into the compost pit. • The pit is properly secured by steel wire mesh to prevent rodents or mosquitoes. • At any particular point of time, one compartment is always kept empty to ensure that the churning of the mixture happens properly. • Almost on a daily basis, the mixture from the pits is shuffled from one pit to another. • While churning, add the culture and cow dung on top of the mixture • The compost pits are built to have maximum aeration and have outlets which drains off the compost tea or moisture from the pit. This ensures that the mixture does not stink or create worms. • After 40 days, the compost will be ready in the pit.



Large Scale Composting Pits

USER'S FEEDBACK

Name of the unit: Large Scale Composting Pits

Place of the installation: Millennium D Type Tower, Sector 9, Sanpada, Navi Mumbai

Year of purchase: 2017

Coverage: 156 flats

Cost of the unit: Rs. 2.3 Lakh

Biodegradable waste treated per day: ~ 130 kg

Compost production per day: ~ 65 kg

O & M cost: Cost spent towards sawdust and bioculture @ Rs. 80/kg (comes for a week time)

Processing time: 2 weeks

Usage of compost: Completely used for gardening purpose within the complex

Do's & Don'ts: Non-veg. items should not be treated in the composter.

Contact details of the user: Mr. Ramakrishnan, e-mail: rkdamaraju@gmail.com

2.4: Waste to compost systems for Decentralized Plants for above 1000 Households operated by ULBs / Institutions / Outsourced Agencies

1. Windrow Composting
2. Rotary Drum Composter (Large)
3. Vermi Composter
4. Tallboy

1. Windrow Composting

Sl. No.	Description
1	<p>Specification and Size</p> <ul style="list-style-type: none"> • Windrows are typically trapezoidal in cross section but average windrow shape is between an oval and trapezoidal. A factor of 0.66 is assumed to estimate windrow volumes (Volume = Height x Width x Length x 0.66) • Typically windrows can vary from 2 to 2.3 m in height and 2 to 2.3 m wide at the base. • The space between windrows should be sufficiently wide for movement of the windrow turning machine to be employed in the plant. Normally it is 1-3 m. • Windrow dimensions should allow conservation of heat generated during composting process while also maintaining diffusion of air to the deeper portions of the windrow.
2	<p>Infrastructure Requirements</p> <ul style="list-style-type: none"> • The compost pad (platform) is to be constructed with appropriately designed CC or RCC as per size. The compost pad shall have a slope of about 1% to drain the excess water (storm water or leachate) from the windrows into a leachate collection tank. The leachate tank is placed at the lowest point of the compost pad area. • Factors to be considered in the location and design of the composting pad: <ul style="list-style-type: none"> a) The base has to provide a barrier to prevent percolation of leachate and/or nutrients to the sub-soil and groundwater. b) The surface has to facilitate equipment movement even during wet weather conditions. c) The surface area has to accommodate waste for 5 weeks along with sufficient room for equipment to maneuver and an area to establish a static pile for curing compost at the end of process. • Loader: Tractor mounted front-end loaders or pay loaders are used to deliver the pre-processed feedstock to form windrows. They can also be used for site maintenance, piling the cured compost and loading the finished compost product into trucks or trailers for sale in the market. • Windrow Turner: Generally pay-loaders(wheel or tracked) or tractors with hydraulic attachments are used to scoop the material from one windrow to make a new pile in an adjacent location on the compost pad, while placing and mixing the material. Other equipment such as front end loaders/ windrows re-shifters may also be used for turning windrows. • Screener: A trommel screen is desired at the end of the curing process to screen the finished compost for a suitable particle size. This will remove any larger undesirable items and will fluff up the finished product to ensure a suitable compost quality. • Bagging: Supply of compost is usually in 50/25 kg bags.
3	<p>Operation & Maintenance</p> <ul style="list-style-type: none"> • The pre-processed MSW is transferred onto the compost pad (platform). • Windrow Formation: Windrows can be formed by means of bucket loaders or by manual labour, depending on the size, shape, and spacing of windrows • Windrow Turning: The outer layers of piles are moved to inner layers by turning the windrows. This process is repeated once every week for 5 weeks, high temperatures within the windrow (55 to 65°C) sanitize the material. During the rainy season where the interstitial spaces are filled with water, more frequent turning is necessary (interval of 3-4 days). • A turning schedule should be established based on the rate of decomposition, moisture content, porosity of the material, and the desired composting time (often a function of land availability). • Each windrow should be allowed to stay on the compost pad for 35 days and at the end of the 35th day the compost is ready for sieving. • Each windrow should have a flag board depicting the age of the waste. • Fresh incoming waste is always depicted by "Age 1". The numbering on the windrow changes from Age 1 to Age 2 on the second day; Age 2 should be changed to Age 3 on the third day and so on. • Each windrow may be turned manually or mechanically. This turning process has to be done every 7th day. Hence, only those windrows having a flag board showing Age 7, 14, 21 and 28 should be turned. This turning is modified in rainy day such as every 3,6,9 day etc.

- 3
- Fresh water or leachate stored in the leachate tank should be sprinkled during the turning process to maintain the moisture content of the waste.
 - Figure below shows a quick and simple method to test moisture content.

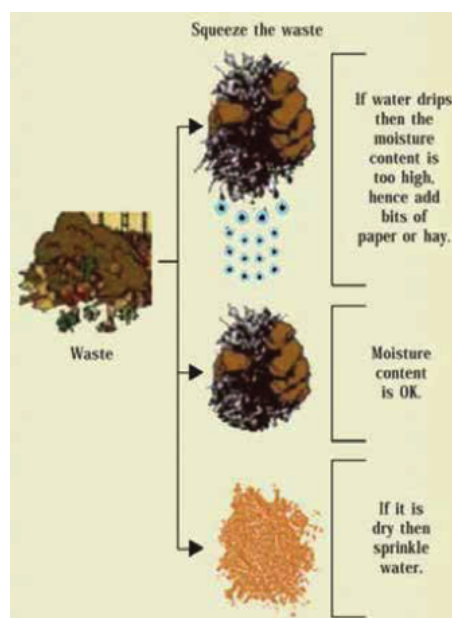

Moisture Content Test

- Temperature should also be monitored and maintained in the range of 55-60°C.
- On the 35th day, the compost is successively sieved through two stage screening system of 35mm followed by 16mm. Screened material coming out of this section is uniform in texture but contains semi-solid organic compost, which requires further stabilization. The rejects from the 35 mm screen are sent to the RDF section and the – 35 mm – material is sent to the 16 mm screen. The rejects from the 16mm (16mm+) screen are to be put back on the windrow as protective covering from bird menace, vermin and for odour control.
- Curing: Screened material coming out of the coarse segregation section requires further maturation and moisture control for producing compost that is beneficial for plants and soil. The curing piles are placed either in a storage area or covered area for a minimum duration of 2 weeks. In general, the area needed for the curing process is one quarter of the size needed for the windrow/composting process. The completely cured well composted material does not have any foul odour and is ready for final screening and marketing.
- The degree of maturity is determined through either oxygen uptake or carbon dioxide production rate. (Determination of maturity is explained in Municipal Solid Waste Management Manual of CPHEEO)
- Compost Refinement: At the end of composting phase, the material usually contains 30 to 35% moisture. The composting is normally taken to be complete when the active decomposition stage is over and the C/N ratio is around 20:1. The refinement section also consists of a feeder conveyer and a trommel with 4mm perforations. The screened product which is less than 4mm is passed through ADS (air density separator or de-stoner) to remove sand and grit. Then the compost can be put in bags and stored for sale. The remaining material greater than 4 mm in size should be put on top of the fresh incoming waste heap, to speed up the process of composting and for absorbing excess moisture. The residue material from the ADS is inert laced with fine organic material. This should be kept out of the composting stream. The finished product is dark brown with an earthy smell, fragile and rich in organic matter content and nutrients.
- Leachate Management: Leachate generated during composting varies with seasons. The compost pad surface should be designed with proper gradient and surface drainage system so that the entire leachate from windrows is directed through drainage system to collection tank. This leachate can be utilized for moistening the waste placed in the windrows, as required. In case leachate production is higher than consumption, the leachate tank should be provided with treatment facilities for treating before disposal. Normally, the leachate tank is provided with a surface aerator for reducing the BOD content. Treated leachate could be subsequently used for as a liquid fertilizer.

(Detailed design of aerobic windrow composting plants from 50 – 500 TPD MSW input capacity is available in the 'Inter-Ministerial Task Force on Integrated Plant

Windrow Size Calculation

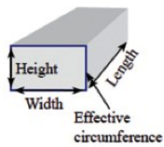

Rectangle
 Volume = Height x Width x Length
 Effective circumference = $2 \times \text{height} + \text{width}$
 Mass = Volume x Bulk Density

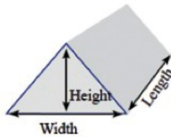

Triangle
 Volume = Height x Width x Length x 0.5
 Effective circumference = $2 \times \sqrt{\text{height}^2 + (\text{width}/2)^2}$
 Mass = Volume x Bulk Density

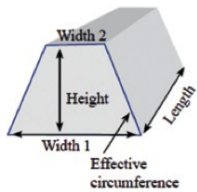

Trapezoid
 Volume = Height x (Width1+Width2) x Length x 0.5
 Effective circumference = $2 \times (\sqrt{((\text{width2}-\text{width1})/2)^2 + \text{height}^2}) + \text{width2}$
 Mass = Volume x Bulk Density

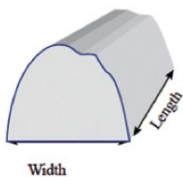

Oval
 Approximations:
 Volume = Height x Width x Length x 0.75
 Effective circumference = $2.3 \times \sqrt{\text{height}^2 + (\text{width}/2)^2}$
 Mass = Volume x Bulk Density

USER'S FEEDBACK

Name of the Technique: Windrows Composting
 Place of the installation: Okhla, Delhi
 Biodegradable waste treated per day: 200 tonnes
 Compost production per day: 30-35 tonnes
 Usage of biogas: Sold to farmers and Fertilizer companies
 Selling price of compost: Rs. 1000/tonne (if sold in loose) & Rs. 2500+packaging & transportation cost (otherwise)
 Do's & Don'ts: Same as the operation & maintenance procedure, above.
 Contact details: Mr. Kapil Gupta, Head, IL&FS Composting Plant, Okhla, Delhi.

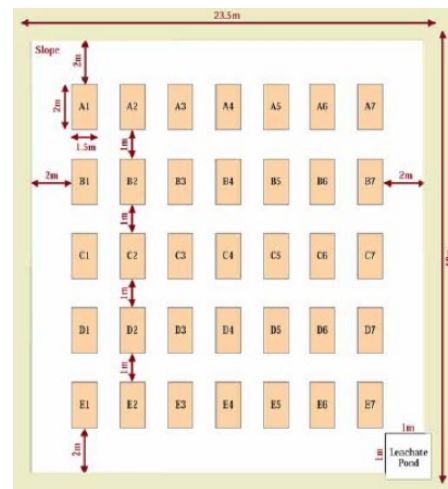

Chart showing arrangement of windrow

Windrow Composting

2. Rotary Drum Composter (Large)

Method	Aerobic
Processing Time	1-7 days
Description	<ul style="list-style-type: none"> • Drum systems typically consist of a steel drum with a diameter between 1.5 and 5 m. • In small-scale systems, the drums have a length of up to 10 m. • By comparison, large-scale systems use drums that are significantly longer (i.e., 30 to 80 m). • The drums are positioned on a slight incline (less than 5%) and rotate at between 0.5 and 5 rotations per minute (rpm). • The combination of the drum's rotation and incline, with gravity, results in materials tumbling down the drum in a corkscrew manner from the upper in-feed end to the lower discharge end. • Air is typically injected into the drums, usually at the discharge end, to meet process air requirements. • The loading and unloading doors and the drive mechanisms introduce a higher degree of mechanical complexity and maintenance requirements relative to other in-vessel composting systems. • Drum capacities for smaller-scale systems range from 5 to 50 m³; • Generally, the drums are loaded to between 65 to 80% of their total volume. Loading more material into the drum prevents materials inside from tumbling and reduces processing efficiency. • A drum's annual capacity is determined by how much is unloaded from the drum and how often. • Rotating drums are usually designed with a composting time of one to seven days. • With composting times this short, the material emerges without having completed the active composting step and needs further treatment.



Rotary Drum Composter

USER'S FEEDBACK

Name of the unit: Rotary Drum Composter (Large)

Place of the installation: Calangute/Saligao, Goa

Year of Commencement: 2016

Cost of plant: Rs. 2.5 crore for each drum composter including technology transfer cost and erection cost

Biodegradable waste treated per day: 15 tonnes of digestate + 10 tonnes bulking materials (wood chips & paper)

Compost production per day: 10-12.5 tonnes

Processing time: 6 days

Usage of compost: Sold to Zuari Agro Chemicals Limited, Goa.

Selling cost of the compost: Rs. 1.5/kg excluding packing and transportation costs

O&M Cost: Rs. 300/ton for 30 tonnes capacity

Do's & Don'ts: C/N ratio is to be properly maintained by adding appropriate materials; the temperature should be maintained between 50-60°C, if there is any decrease in temperature, then the load shall be reduced.

Contact details of the user: Mr. Ganesh, e-mail: ganesh@intergeoindia.com

3. Vermi Composter

Provider	Vermigold Ecotech Ltd
Method	Aerobic
Capacity	50 kg - 3 tons
Ideal Community Size	50 - 3000 HH
Add-on Supplies	Dry leaves
Infrastructure	9 sq. metres /50 households
Processing Time	10 days
Investment Cost	~Rs. 4 lakhs/ 50 HH, Rs. 13.5 lakhs/500 HH
Running Cost	Power is required for shredder
Operation & maintenance	<ul style="list-style-type: none"> • Mix the segregated food waste with cardboard and garden waste in the organic waste shredder in 80:20 ratio by weight and 1:1 by volume, respectively (Food waste: dry/leaves cardboard). • Spread the output evenly in each of the 4 cells of the Digester. • Spread a layer of old manure over the fresh food waste to prevent flies from getting attracted to the food waste. • Ensure that the jute bags cover the top of all the cells. • Spray the cells with water once (approx 1 litre per cell). • After the operation is over, ensure that the roofs properly cover all the cells. • The cells should be poked daily from top to bottom and the area should be kept clean. Non poking of cells will lead to foul odours. • For the first 2 months recycle 100% manure back into system to stabilize system operations.
Contact	Email: manohar.v@vermigold.com Phone: +91 888 4444 121, Website: www.vermigold.com



Vermi Composter

USER'S FEEDBACK

Name of the unit: Vermigold

Place of the installation: Hotel Holiday Inn, Mayur Vihar, New Delhi

Year of purchase: 2015

Cost of unit: 3.5 lakhs for 50 kg plant

Biodegradable waste treated per day: ~ 100 kg

Compost production per day: ~ 10 kg

O & M cost: Negligible

Processing time: 8-10 days

Usage of compost: completely used for gardening purpose within the campus

Do's & Don'ts: Mixing of garden waste or cardboard will help in adequate mixing and hence will reduce the cycle time.

Contact details of the user: Ms. Aastha Sukhija, e-mail: aastha.sukhija@ihg.com

4. Tallboy

Provider	Rite-ways
Method	Aerobic
Capacity	150 KGs upto 2 MT
Ideal Community Size	100 - 2000 households
Add-on Supplies	saw dust/ cocopeat, bioculture
Infrastructure	10 Sq.ft. to 60 sq.ft can be kept outside. Needs shelter space for pulverizers
Processing Time	15 days
Investment Cost	Rs. 2 lakhs - 6 lakhs
Running Cost	Rs.2000/- per month
Operation & maintenance	<ul style="list-style-type: none"> • The segregated waste is mixed with old compost and bioculum. • The mixed waste is grinded finely in the pulveriser. • Fill the finely grinded waste in even layers in the biobins. • Repeat the procedure every day for 15 days. • From 16th day the compost can be harvested from the bottom of the biobin in layers.
Contact	Email: monika@rite-ways.com Phone: 919980780570, Website: www.rite-ways.com



Tallboy

USER'S FEEDBACK

Name of the unit: Tall Boy

Place of the installation: Keys Hotel, White Field, Bengaluru

Year of purchase: 2016

Cost of unit: 3.5 Lakh

Biodegradable waste treated per day: 60 – 70 kg

Compost production per day: ~ 10 kg

O & M cost: Rs. 3000-3500/ month for the purchase of bioculum (100 gm/day @ Rs. 2000/5 kg) and sawdust (for 20 % by the weight of the waste @ Rs. 5 /kg)

Usage of compost: 50 % is used for gardening purpose within the campus and rest is being sold to nursery

Selling price of the compost: Rs. 5/kg

Do's & Don'ts: Same as the operation & maintenance procedure, above.

Contact details of the user: Mr. Nayaz, e-mail: engg.blr-ws@sofitel.com

2.5: Nirmalaya

1. Temple Flowers Waste Recycling to Agarbatti Making in Shirdi, Maharashtra

1. Temple Flowers Waste Recycling to Agarbatti Making in Shirdi, Maharashtra

S No.	Work Sequence - Description
1	Collection of Pooja Flowers: The Women Self-Help Group (SHG) appointed Jansewa Foundation collect the flowers from Shri Saibaba Samadhi Mandir Trust (SSSMT) in three shifts. The flowers are transported in a ventilated vehicle, weight recorded and sent to processing unit at Pravaranagar, 35 Kms away from Shirdi. (Average 02 trips / day & 2 MT i.e. 1 MT / trip). Labour : 1 Supervisor & 6 women in each shift, 1 driver in two shifts
2	Pre-processing & Segregation of Petals: Floral waste is segregated and petals extracted in the categories of (1) Rose, (2) Marigold (3) Basil. Leaves are also separated. Each fraction is put in separate plastic crates and weighed for each women worker for payment. The crates are also given lot number and date of extraction for processing control. Labour: 20 women / 1 supervisor
3	Drying of Flower Petals: Rose petals are dried by spreading on the nursery green cloth under the sun. Drying is completed in 4-6 days depending on the weather. Turning over of petals is done for uniform and quick drying. Dried petals are picked up and stacked in netted poly bags (recycled sugar, cement, grain bags).
4	Pulverisation of Flower Petals: The fully dried petals are put into a pulverizer machine and are pulverized to a size of 0.5 to 0.8 mm. The pulverized powder is sieved (on vibrator) to remove bigger sized particles. Labour: 3 women for placing the petals & stacking the powder.
5	Agarbatti Making Preparation of mix: The agarbatti base is prepared in the ratio of rose petal powder 1 kg : Binding agent 200 gms : water 1 Litre (RO). Batches of agarbatti mix are prepared as per this proportion and thoroughly mixed for 2 minutes in a mechanical mixer and prepared as per quantity requirements so that the setting time does not exceed limits. Labour: 2 women for handling & its storage after filtration.
6	Agarbatti Making: The Agarbatti mix is coated on to the bamboo sticks by a machine. Every agarbatti stick is visually checked and defective ones are immediately removed and reused for quality control and zero wastage. Manpower: 01 operator & 01 helper to place the agarbatti in dryer.
7.	Drying of Agarbatti: Drying is carried out in a machine in a time of 12-14 hrs depending upon the weather. If necessary, the agarbattis are dried on the floor mat also. Bundles of 500 gm each are made and tied together for straightness and for processing in the next stage. Labour: 4 women for handling the agarbatti
8	Adding Perfume to the Agarbatti: The perfume mix is prepared in the ratio 1 part of perfume: 3 parts of DEP (Diethyl phthalate). The dried agarbattis are then placed in the perfume dipping machine drum which is rotated for about 2 minutes for the sticks to absorb perfume. They are then removed and unbundled to dry on trays or on matted floors. Labour: 1 operator & 1 helper for executing entire process.
9	Final Packing: The fully manufactured sticks are again visually inspected for quality control and good ones are packed in butter paper for 30 sticks each and placed inside the boxes. Finally, the product is taken to the sales counter. Labour: 4 to 6 helpers based on the availability of incense sticks
10	Sale of Agarbattis: These agarbattis made out of the Pooja flowers (Rose petals) have a captive selling arrangement with the SSSMT. The Trust has allotted a counter in temple premises for the sale of these agarbattis..There is a heavy demand by the pilgrims for these agarbattis as they are manufactured out of the flowers offered in Pooja to Shri Shirdi Saibaba. Labour: 2-3 women
11	Profit Sharing: Three parties are involved in this entire process: Shri Saibaba Samadhi Mandir Trust (SSSMT) Jansewa Foundation – NGO-(SHG) Eckonirmitee Infrastructure Pvt. Ltd.(Technology and Equipment provider) Profits are shared as 10% to the SSSMT and License Fee as per agreement to the technology provider and the rest to the NGO-SHG group. On an average each women worker earns Rs. 6,000./- per month and 80 number of women workers are employed.

<p>Name of the unit: Temple Flowers Waste Recycling to Agarbatti Making in Shirdi, Maharashtra</p> <p>Place of the installation: Pravaranagar</p> <p>Year of Commencement: 2018</p> <p>Quantity of Flowers treated per day: 2.0 MT</p> <p>Processing time: 15-20 Days</p> <p>Agarbatti production per day: 80 kg /day, (88,000 sticks, 2950 packets /day)</p> <p>Cost /Packet: Rs.22.5</p> <p>Selling price of Agarbatti: Rs. 30 /packet</p> <p>Usage of Agarbatti: Completely used in the same premises of Shirdi Sansthan in Pooja to Shirdi Saibaba.</p> <p>Contact details of the user including mobile no. & e-mail address: Rupali K.Londhe, Janseva Foundation, Loni. Mob-09960408899, Email - londherk2015@gmail.com Ravindra M Desai, Eckonirmitee Infrastructure Pvt. Ltd. Ph-09833636895, 08355921126, Email -rmdesai71@gmail.com</p>
--

Photographs

Collection of Pooja Flowers	
Pre-processing & Segregation of Petals	
Drying of Flower Petals	
Pulverisation of Flower Petals	
Agarbatti Making Preparation of mix	

<p>Agarbatti making</p>	
<p>Drying of Agarbatti:</p>	
<p>Adding Perfume to the Agarbatti</p>	
<p>Final Packing Sale & Marketing</p>	<div data-bbox="479 1131 983 1326" style="border: 1px solid black; padding: 5px;"> <p>शिरडी की साईं की चढाये गुलाब से बनती अगर्बती, ये प्रसाद है साईं का।</p> <p>शिरडी की साईं की चढाये गुलाब से बनती अगर्बती, ये प्रसाद है साईं का।</p> <p>Sai Dwarakata Agarbatti made from the floral offerings with devotion at holy shrine of Sai Baba, Shirdi, Shirdi is a sacred spiritual boon. This incense stick will infuse the positivity & calmness in environment around you with the blessings of Sai Baba.</p> <p>शिरडी की साईं की चढाये गुलाब से बनती अगर्बती, ये प्रसाद है साईं का।</p> </div>

End Note

In order to reduce the burden of unscientific handling of large volumes of MSW, it is time for the ULBs to shift their focus from centralised 'single stream' collection and 'dump/Landfill disposal' system to a decentralised 'multiple stream' collection and scientific decentralised 'Processing' system.

Based on the stream of waste and its generation, the appropriate method of treatment/methods and the scale of treatment units (Community/Ward/Division/Zone/City level) have to be selected.

The onsite and decentralised organic waste treatment methods herein may be used as reference guides for the selecting a suitable method/practice by the stakeholders for managing their solid waste at source itself or as close to source as possible. Such practices

will deliver several advantages for all stakeholders as compared to the usual practice of extended chains of collection & transportation with 'end of pipe' treatment. Some of the advantages are listed below:

1. Reduction in the collection and transportation chain of MSWM and costs thereof.
2. Reduction in GHG emissions due to uncontrolled putrefaction /decay of biodegradable waste due to extended collection and transportation chains.
3. Reduction in smell/bad odour at the premises / storage points and roads & streets.
4. Elimination of uncontrolled leachate.
5. Shorter the collection & transport chain, better the quality of City compost.
6. Decentralised City compost producers are more likely to use the compost themselves or develop strong off-take arrangements.

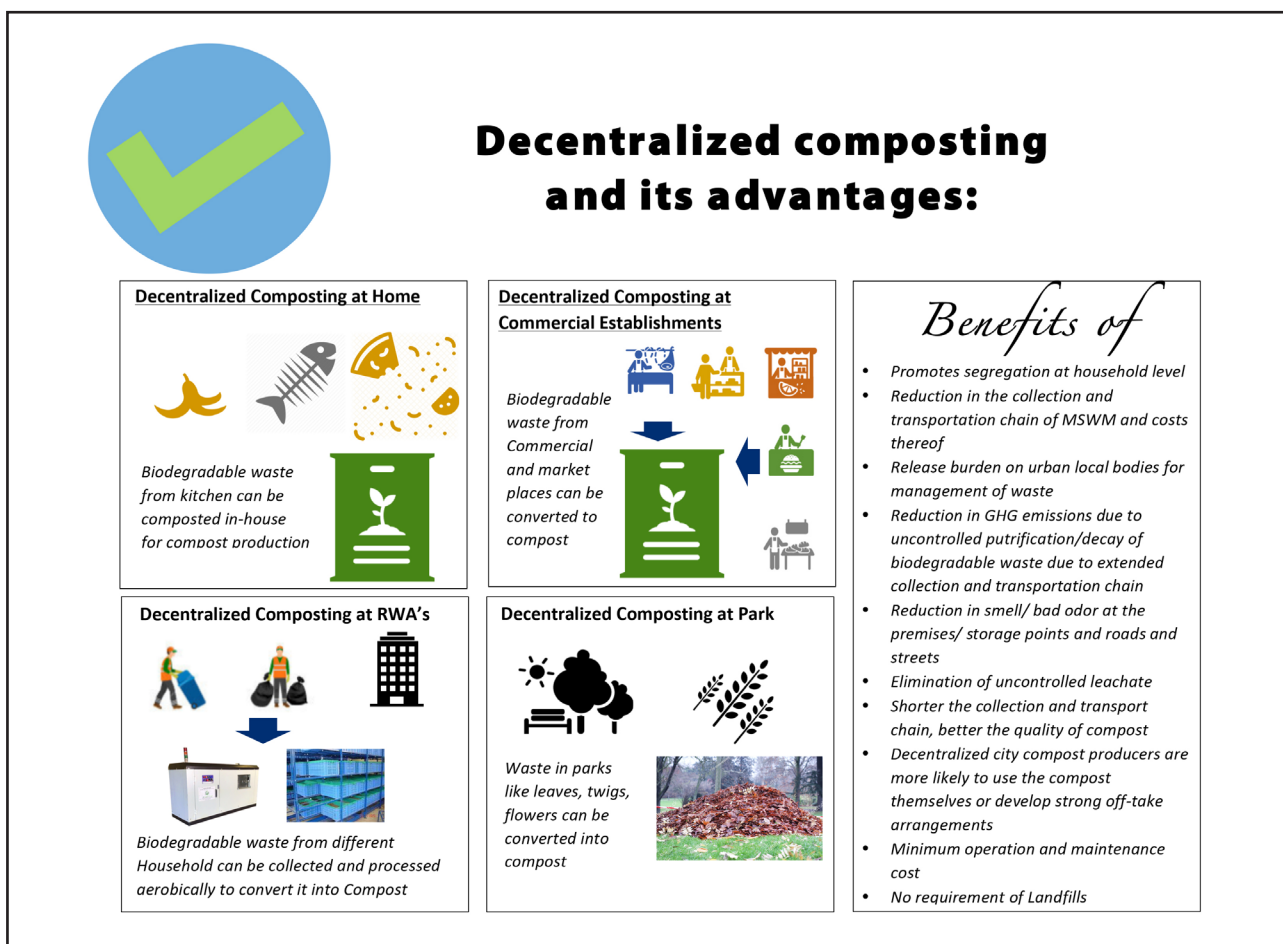
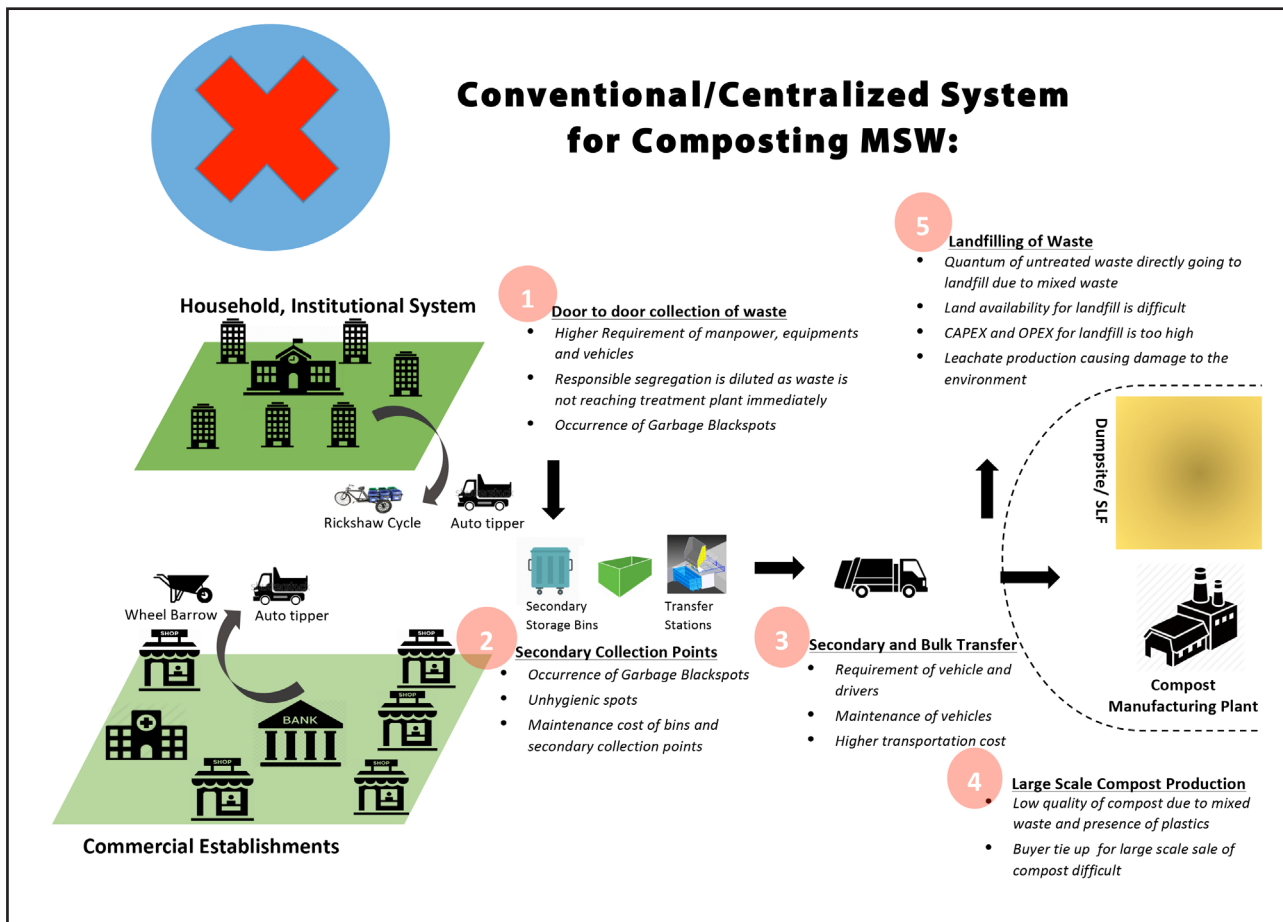

Bio-Medical Waste Management Rules, 2016

SCHEDULE I

[See rules 3 (e), 4(b), 7(1), 7(2), 7(5), 7 (6) and 8(2)]

Part-1

Biomedical wastes categories and their segregation, collection,
treatment, processing and disposal options

Category	Type of Waste	Type of Bag or Container to be used	Treatment and Disposal options
(1)	(2)	(3)	(4)
Yellow	(a) Human Anatomical Waste: Human tissues, organs, body parts and fetus below the viability period (as per the Medical Termination of Pregnancy Act 1971,	Yellow coloured non-chlorinated plastic bags	Incineration or Plasma Pyrolysis or deep burial*
	b) Animal Anatomical Waste: Experimental animal carcasses, body parts, organs, tissues, including the waste generated from animals used in experiments or testing in veterinary hospitals or		
	c) Soiled Waste: Items contaminated with blood, body fluids like dressings, plaster casts, cotton swabs and bags containing residual or discarded blood and blood components		Incineration or Plasma Pyrolysis or deep burial* In absence of above facilities, autoclaving or micro-waving/ hydroclaving followed by shredding or mutilation or combination of sterilization and shredding. Treated waste to be sent for energy recovery.
	(d) Expired or Discarded Medicines: Pharmaceutical waste like antibiotics, cytotoxic drugs including all items contaminated with cytotoxic drugs along with glass or plastic ampoules, vials etc.	Yellow coloured non-chlorinated plastic bags or containers	Expired cytotoxic drugs and items contaminated with cytotoxic drugs to be returned back to the manufacturer or supplier for incineration at temperature >1200oC or to common bio-medical waste treatment facility or hazardous waste treatment, storage and disposal facility for incineration at >1200oC Or Encapsulation or Plasma Pyrolysis at >1200oC. All other discarded medicines shall be either sent back to manufacturer or disposed by incineration.

	<p>(e) Chemical Waste: Chemicals used in production of biological and used or discarded disinfectants.</p>	Yellow coloured containers or non-chlorinated plastic bags	Disposed of by incineration or Plasma Pyrolysis or Encapsulation in hazardous waste treatment, storage and disposal facility.
	<p>(f) Chemical Liquid Waste: Liquid waste generated due to use of chemicals in production of biological and used or discarded disinfectants, Silver X-ray film developing liquid, discarded Formalin, infected secretions, aspirated body fluids, liquid from laboratories and floor washings, cleaning, house- keeping and disinfecting activities etc.</p>	Separate collection system leading to effluent treatment system	After resource recovery, the chemical liquid waste shall be pre-treated before mixing with other wastewater. The combined discharge shall conform to the discharge norms given in Schedule- III.
	<p>(g) Discarded linen, mattresses, beddings contaminated with blood or body fluid.</p>	Non-chlorinated yellow plastic bags or suitable packing material	Non- chlorinated chemical disinfection followed by incineration or Plazma Pyrolysis or for energy recovery. In absence of above facilities, shredding or mutilation or combination of sterilization and shredding. Treated waste to be sent for energy recovery or incineration or Plazma Pyrolysis.
	<p>(h) Microbiology, Biotechnology and other clinical laboratory waste: Blood bags, Laboratory cultures, stocks or specimens of micro- organisms, live or attenuated vaccines, human and animal cell cultures used in research, industrial biological, residual toxins, dishes and devices used for cultures, laboratories, production of biological, residual toxins, dishes and devices used for cultures.</p>	Autoclave safe plastic bags or containers	Pre-treat to sterilize with non-chlorinated chemicals on-site as per National AIDS Control Organisation or World Health Organisation guidelines thereafter for Incineration.
Red	<p>Contaminated Waste (Recyclable) (a) Wastes generated from disposable items such as tubing, bottles, intravenous tubes and sets, catheters, urine bags, syringes (without needles and fixed needle syringes) and vaccutainers with their needles cut) and gloves.</p>	Red coloured non- chlorinated plastic bags or containers	Autoclaving or micro-waving/ hydroclaving followed by shredding or mutilation or combination of sterilization and shredding. Treated waste to be sent to registered or authorized recyclers or for energy recovery or plastics to diesel or fuel oil or for road making, whichever is possible. Plastic waste should not be sent to landfill sites.

White (Translucent)	Waste sharps including Metals: Needles, syringes with fixed needles, needles from needle tip cutter or burner, scalpels, blades, or any other contaminated sharp object that may cause puncture and cuts. This includes both used, discarded and contaminated metal sharps	Puncture proof, Leak proof, tamper proof containers	Autoclaving or Dry Heat Sterilization followed by shredding or mutilation or encapsulation in metal container or cement concrete; combination of shredding cum autoclaving; and sent for final disposal to iron foundries (having consent to operate from the State Pollution Control Boards or Pollution Control Committees) or sanitary landfill or designated concrete waste sharp pit.
Blue	(a) Glassware: Broken or discarded and contaminated glass including medicine vials and ampoules except those contaminated with cytotoxic wastes.	Cardboard boxes with blue colored marking	Disinfection (by soaking the washed glass waste after cleaning with detergent and Sodium Hypochlorite treatment) or through autoclaving or microwaving or hydroclaving and then sent for recycling.

*Disposal by deep burial is permitted only in rural or remote areas where there is no access to common bio- medical waste treatment facility. This will be carried out with prior approval from the prescribed authority and as per the Standards specified in Schedule-III. The deep burial facility shall be located as per the provisions and guidelines issued by Central Pollution Control Board from time to time.

Part -2

1. All plastic bags shall be as per BIS standards as and when published, till then the prevailing Plastic Waste Management Rules shall be applicable.
2. Chemical treatment using at least 10% Sodium Hypochlorite having 30% residual chlorine for twenty minutes or any other equivalent chemical reagent that should demonstrate Log104 reduction efficiency for microorganisms as given in Schedule- III.
3. Mutilation or shredding must be to an extent to prevent unauthorized reuse.
4. There will be no chemical pretreatment before incineration, except for microbiological, lab and highly infectious waste.
5. Incineration ash (ash from incineration of any bio-medical waste) shall be disposed through hazardous waste treatment, storage and disposal facility, if toxic or hazardous constituents are present beyond the prescribed limits as given in the Hazardous Waste (Management, Handling and Transboundary Movement) Rules, 2008 or as revised from time to time.
6. Dead Fetus below the viability period (as per the Medical Termination of Pregnancy Act 1971, amended from time to time) can be considered as human anatomical waste. Such waste should be handed over to the operator of common bio-medical waste treatment and disposal facility in yellow bag with a copy of the official Medical Termination of Pregnancy certificate from the Obstetrician or the Medical Superintendent of hospital or healthcare establishment.
7. Cytotoxic drug vials shall not be handed over to unauthorised persons under any circumstances. These shall be sent back to the manufactures for necessary disposal at a single point. As a second option, these may be sent for incineration at common bio-medical waste treatment and disposal facility or TSDFs or plasma pyrolysis is at temperature $>1200^{\circ}\text{C}$.
8. Residual or discarded chemical wastes, used or discarded disinfectants and chemical sludge can be disposed at hazardous waste treatment, storage and disposal facility. In such case, the waste should be sent to hazardous waste treatment, storage and disposal facility through operator of common bio-medical waste treatment and disposal facility only.
9. On-site pre-treatment of laboratory waste, microbiological waste, blood samples, blood bags should be disinfected or sterilized as per the Guidelines of World Health Organisation or National AIDS Control Organisation and then given to the common bio-medical waste treatment and disposal facility.
10. Installation of in-house incinerator is not allowed. However in case there is no common biomedical facility nearby, the same may be installed by the occupier after taking authorisation from the State Pollution Control Board.
11. Syringes should be either mutilated or needles should be cut and or stored in tamper proof, leak proof and puncture proof containers for sharps storage. Wherever the occupier is not linked to a disposal facility it shall be the responsibility of the occupier to sterilize and dispose in the manner prescribed.
12. Bio-medical waste generated in households during healthcare activities shall be segregated as per these rules and handed over in separate bags or containers to municipal waste collectors. Urban Local Bodies shall have tie up with the common bio-medical waste treatment and disposal facility to pickup this waste from the Material Recovery Facility (MRF) or from the house hold directly, for final disposal in the manner as prescribed in this Schedule.

**Hazardous and Other Wastes (Management
and Transboundary Movement) Rules, 2016**
SCHEDULE I

[See rule 3 (1) (17) (i)]

List of processes generating hazardous Wastes

S.No.	Processes	Hazardous Waste*
(1)	(2)	(3)
1.	Petrochemical processes and pyrolytic operations	1.1 Furnace or reactor residue and debris 1.2 Tarry residues and still bottoms from distillation 1.3 Oily sludge emulsion 1.4 Organic residues 1.5 Residues from alkali wash of fuels 1.6 Spent catalyst and molecular sieves 1.7 Oil from wastewater treatment
2.	Crude oil and natural gas production	1.1 Drill cuttings excluding those from water based mud 1.2 Sludge containing oil 1.3 Drilling mud containing oil
3.	Cleaning, emptying and maintenance of petroleum oil storage tanks including ships	1.1 cargo residue, washing water and sludge containing oil 1.2 cargo residue and sludge containing chemicals 1.3 Sludge and filters contaminated with oil 1.4 Ballast water containing oil from ships
4.	Petroleum refining or re- processing of used oil or recycling of waste oil	1.1 Oil sludge or emulsion 1.2 Spent catalyst 1.3 Slop oil 1.4 Organic residue from processes 1.5 Spent clay containing oil
5.	Industrial operations using mineral or synthetic oil as lubricant in hydraulic systems or other applications	1.1 Used or spent oil 1.2 Wastes or residues containing oil 1.3 Waste cutting oils
6.	Secondary production and / or industrial use of zinc	1.1 Sludge and filter press cake arising out of production of Zinc Sulphate and other Zinc Compounds. 1.2 Zinc fines or dust or ash or skimmings in dispersible form 1.3 Other residues from processing of zinc ash or skimmings 1.4 Flue gas dust and other particulates

7.	Primary production of zinc or lead or copper and other non-ferrous metals except aluminium	<ul style="list-style-type: none"> 1.1 Flue gas dust from roasting 1.2 Process residues 1.3 Arsenic-bearing sludge 1.4 Non-ferrous metal bearing sludge and residue. 1.5 Sludge from scrubbers
8.	Secondary production of copper	<ul style="list-style-type: none"> 1.1 Spent electrolytic solutions 1.2 Sludge and filter cakes 1.3 Flue gas dust and other particulates
9.	Secondary production of lead	<ul style="list-style-type: none"> 1.1 Lead bearing residues 1.2 Lead ash or particulate from flue gas 1.3 Acid from used batteries
10.	Production and/or industrial use of cadmium and arsenic and their compounds	<ul style="list-style-type: none"> 1.1 Residues containing cadmium and arsenic
11.	Production of primary and secondary aluminum	<ul style="list-style-type: none"> 1.1 Sludges from off-gas treatment 1.2 Cathode residues including pot lining wastes 1.3 Tar containing wastes 1.4 Flue gas dust and other particulates 1.5 Drosses and waste from treatment of salt sludge 1.6 Used anode butts 1.7 Vanadium sludge from alumina refineries
12.	Metal surface treatment, such as etching, staining, polishing, galvanizing, cleaning, degreasing, plating, etc.	<ul style="list-style-type: none"> 1.1 Acidic and alkaline residues 1.2 Spent acid and alkali 1.3 Spent bath and sludge containing sulphide, cyanide and toxic metals 1.4 Sludge from bath containing organic solvents 1.5 Phosphate sludge 1.6 Sludge from staining bath 1.7 Copper etching residues 1.8 Plating metal sludge
13.	Production of iron and steel including other ferrous alloys (electric furnace; steel rolling and finishing mills; Coke oven and by products plant)	<ul style="list-style-type: none"> 1.1 Spent pickling liquor 1.2 Sludge from acid recovery unit 1.3 Benzol acid sludge 1.4 Decanter tank tar sludge 1.5 Tar storage tank residue 1.6 Residues from coke oven by product plant.
14.	Hardening of steel	<ul style="list-style-type: none"> 1.1 Cyanide-, nitrate-, or nitrite -containing sludge 1.2 Spent hardening salt
15.	Production of asbestos or asbestos-containing materials	<ul style="list-style-type: none"> 1.1 Asbestos-containing residues 1.2 Discarded asbestos 1.3 Dust or particulates from exhaust gas treatment.
16.	Production of caustic soda and chlorine	<ul style="list-style-type: none"> 1.1 Mercury bearing sludge generated from mercury cell process 1.2 Residue or sludges and filter cakes 1.3 Brine sludge

17.	Production of mineral acids	1.1 Process acidic residue, filter cake, dust 1.2 Spent catalyst
18.	Production of nitrogenous and complex fertilizers	1.1 Spent catalyst 1.2 Carbon residue 1.3 Sludge or residue containing arsenic 1.4 Chromium sludge from water cooling tower
19.	Production of phenol	1.1 Residue or sludge containing phenol 1.2 Spent catalyst
20.	Production and/or industrial use of solvents	1.1 Contaminated aromatic, aliphatic or napthenic solvents may or may not be fit for reuse. 1.2 Spent solvents 1.3 Distillation residues 1.4 Process Sludge
21.	Production and/or industrial use of paints, pigments, lacquers, varnishes and inks	1.1 Process wastes, residues and sludges 1.2 Spent solvent
22.	Production of plastics	1.1 Spent catalysts 1.2 Process residues
23.	Production and /or industrial use of glues, organic cements, adhesive and resins	1.1 Wastes or residues (not made with vegetable or animal materials) 1.2 Spent solvents
24.	Production of canvas and textiles	1.1 Chemical residues
25.	Industrial production and formulation of wood preservatives	1.1 Chemical residues 1.2 Residues from wood alkali bath
26.	Production or industrial use of synthetic dyes, dye-intermediates and pigments	1.1 Process waste sludge/residues containing acid, toxic metals, organic compounds 1.2 Dust from air filtration system 1.3 Spent acid 1.4 Spent solvent 1.5 Spent catalyst
27.	Production of organic-silicone compound	1.1 Process residues
28.	Production/formulation of drugs/ pharmaceutical and health care product	1.1 Process Residue and wastes 1.2 Spent catalyst 1.3 Spent carbon 1.4 Off specification products 1.5 Date-expired products 1.6 Spent solvents
29.	Production, and formulation of pesticides including stock-piles	1.1 Process wastes or residues 1.2 Sludge containing residual pesticides 1.3 Date-expired and off-specification pesticides 1.4 Spent solvents 1.5 Spent catalysts 1.6 Spent acids
30.	Leather tanneries	1.1 Chromium bearing residue and sludge

31.	Electronic Industry	1.1 Process residue and wastes 1.2 Spent etching chemicals and solvents
32.	Pulp and Paper Industry	1.1 Spent chemicals 1.2 Corrosive wastes arising from use of strong acid and bases 1.3 Process sludge containing adsorbable organic halides(AOX)
33.	Handling of hazardous chemicals and wastes	1.1 Empty barrels/containers/liners contaminated with hazardous chemicals 1.2 /wastes 1.3 Contaminated cotton rags or other cleaning materials
34.	De-contamination of barrels / containers used for handling of hazardous wastes/chemicals	1.1 Chemical-containing residue arising from decontamination. 1.2 Sludge from treatment of waste water arising out of cleaning / disposal of barrels / containers
35.	Purification and treatment of exhaust air/ gases, water and waste water from the processes in this schedule and common industrial effluent treatment plants (CETP's)	1.1 Exhaust Air or Gas cleaning residue 1.2 Spent ion exchange resin containing toxic metals 1.3 Chemical sludge from waste water treatment 1.4 Oil and grease skimming 1.5 Chromium sludge from cooling water
36.	Purification process for organic compounds/solvents	1.1 Any process or distillation residue 1.2 Spent carbon or filter medium
37.	Hazardous waste treatment processes, e.g. pre-processing, incineration and concentration	1.1 Sludge from wet scrubbers 1.2 Ash from incinerator and flue gas cleaning residue 1.3 Concentration or evaporation residues
38.	Chemical processing of Ores containing heavy metals such as Chromium, Manganese, Nickel, Cadmium etc.	1.1 Process residues 1.2 Spent acid

* The inclusion of wastes contained in this Schedule does not preclude the use of Schedule II to demonstrate that the waste is not hazardous. In case of dispute, the matter would be referred to the Technical Review Committee constituted by Ministry of Environment, Forest and Climate Change.

Note: The high volume low effect wastes such as fly ash, Phosphogypsum, red mud, jarosite, Slags from pyrometallurgical operations, mine tailings and ore beneficiation rejects are excluded from the category of hazardous wastes. Separate guidelines on the management of these wastes shall be issued by Central Pollution Control Board.

Hazardous and Other Wastes (Management and Transboundary Movement) Rules, 2016 SCHEDULE II

[See rule 3 (1) (17) (ii)]

List of waste constituents with concentration limits

Class A: Based on leachable concentration limits [Toxicity Characteristic Leaching Procedure (TCLP) or Soluble Threshold Limit Concentration (STLC)]

Class	Constituents	Concentration in mg/l
(1)	(2)	(3)
A1	Arsenic	5.0
A2	Barium	100.0
A3	Cadmium	1.0
A4	Chromium and/or Chromium (III) compounds	5.0
A5	Lead	5.0
A6	Manganese	10.0
A7	Mercury	0.2
A8	Selenium	1.0
A9	Silver	5.0
A10	Ammonia	50*
A11	Cyanide	20*
A12	Nitrate (as nitrate-nitrogen)	1000.0
A13	Sulphide (as H ₂ S)	5.0
A14	1,1-Dichloroethylene	0.7
A15	1,2-Dichloroethane	0.5
A16	1,4-Dichlorobenzene	7.5
A17	2,4,5-Trichlorophenol	400.0
A18	2,4,6-Trichlorophenol	2.0
A19	2,4-Dinitrotoluene	0.13
A20	Benzene	0.5
A21	Benzo (a) Pyrene	0.001
A22	Bromodichloromethane	6.0
A23	Bromoform	10.0

A24	Carbon tetrachloride	0.5
A25	Chlorobenzene	100.0
A26	Chloroform	6.0
A27	Cresol (ortho+ meta+ para)	200.0
A28	Dibromochloromethane	10.0
A29	Hexachlorobenzene	0.13
A30	Hexachlorobutadiene	0.5
A31	Hexachloroethane	3.0
A32	Methyl ethyl ketone	200.0
A33	Naphthalene	5.0
A34	Nitrobenzene	2.0
A35	Pentachlorophenol	100.0
A36	Pyridine	5.0
A37	Tetrachloroethylene	0.7
A38	Trichloroethylene	0.5
A39	Vinyl chloride	0.2
A40	2,4,5-TP (Silvex)	1.0
A41	2,4-Dichlorophenoxyacetic acid	10.0
A42	Alachlor	2.0
A43	Alpha HCH	0.001
A44	Atrazine	0.2
A45	Beta HCH	0.004
A46	Butachlor	12.5
A47	Chlordane	0.03
A48	Chlorpyriphos	9.0
A49	Delta HCH	0.004
A50	Endosulfan (alpha+ beta+ sulphate)	0.04
A51	Endrin	0.02
A52	Ethion	0.3
A53	Heptachlor (& its Epoxide)	0.008
A54	Isoproturon	0.9
A55	Lindane	0.4
A56	Malathion	19
A57	Methoxychlor	10

A58	Methyl parathion	0.7
A59	Monocrotophos	0.1
A60	Phorate	0.2
A61	Toxaphene	0.5
A62	Antimony	15
A63	Beryllium	0.75
A64	Chromium (VI)	5.0
A65	Cobalt	80.0
A66	Copper	25.0
A67	Molybdenum	350
A68	Nickel	20.0
A69	Thallium	7.0
A70	Vanadium	24.0
A71	Zinc	250
A72	Fluoride	180.0
A73	Aldrin	0.14
A74	Dichlorodiphenyltrichloroethane (DDT), Dichlorodiphenyldichloroethylene (DDE), Dichlorodiphenyldichloroethane (DDD)	0.1
A75	Dieldrin	0.8
A76	Kepone	2.1
A77	Mirex	2.1
A78	Polychlorinated biphenyls	5.0
A79	Dioxin (2,3,7,8-TCDD)	0.001

Class B: Based on Total Threshold Limit Concentration (TTLC)

Class	Constituent	Concentration in mg/kg
(1)	(2)	(3)
B1	Asbestos	10000
B2	Total Petroleum Hydrocarbons (TPH) (C5 - C36)	5,000

Note:

- (1) The testing method for list of constituents at A1 to A61 in Class-A, shall be based on Toxicity Characteristic Leaching Procedure (TCLP) and for extraction of leachable constituents, USEPA Test Method 1311 shall be used.
- (2) The testing method for list of constituents at A62 to A79 in Class- A, shall be based on Soluble Threshold Limit Concentration (STLC) and Waste Extraction Test (WET) Procedure given in Appendix II of section 66261 of Title 22 of California Code regulation (CCR) shall be used.
- (3) In case of ammonia (A10), cyanide (A11) and chromium VI (A64), extractions shall be conducted using distilled water in place of the leaching media specified in the TCLP/STLC procedures.
- (4) A summary of above specified leaching/extraction procedures is included in manual for characterization and analysis of hazardous waste published by Central Pollution Control Board and in case the method is not covered in the said manual, suitable reference method may be adopted for the measurement.
- (5) In case of asbestos, the specified concentration limits apply only if the substances are in a friable, powdered or finely divided state.
- (6) The hazardous constituents to be analyzed in the waste shall be relevant to the nature of the industry and the materials used in the process.
- (7) Wastes which contain any of the constituents listed below shall be considered as hazardous, provided they exhibit the characteristics listed in Class-C of this Schedule :

1.	Acid Amides
2.	Acid anhydrides
3.	Amines
4.	Anthracene
5.	Aromatic compounds other than those listed in Class A
6.	Bromates, (hypo-bromites)
7.	Chlorates (hypo-chlorites)
8.	Carbonyls
9.	Ferro-silicate and alloys
10.	Halogen- containing compounds which produce acidic vapours on contact with humid air or water e.g. silicon tetrachloride, aluminum chloride, titanium tetrachloride
11.	Halogen- silanes
12.	Halogenated Aliphatic Compounds
13.	Hydrazine (s)
14.	Hydrides
15.	Inorganic Acids
16.	Inorganic Peroxides
17.	Inorganic Tin Compounds
18.	Iodates
19.	(Iso- and thio-) Cyanates
20.	Manganese-silicate
21.	Mercaptans
22.	Metal Carbonyls
23.	Metal hydrogen sulphates
24.	Nitrides
25.	Nitriles

26.	Organic azo and azoxy Compounds
27.	Organic Peroxides
28.	Organic Oxygen Compounds
29.	Organic Sulphur Compounds
30.	Organo- Tin Compounds
31.	Organo nitro- and nitroso compounds
32.	Oxides and hydroxides except those of hydrogen, carbon, silicon, iron, aluminum, titanium, manganese, magnesium, calcium
33.	Phenanthrene
34.	Phenolic Compounds
35.	Phosphate compounds except phosphates of aluminum, calcium and iron
36.	Salts of pre-acids
37.	Total Sulphur
38.	Tungsten Compounds
39.	Tellurium and tellurium compounds
40.	White and Red Phosphorus
41.	2-Acetylaminofluorene
42.	4-Aminodiphenyl
43.	Benzidine and its salts
44.	Bis (Chloromethyl) ether
45.	Methyl chloromethyl ether
46.	1,2-Dibromo-3-chloropropane
47.	3,3'-Dichlorobenzidine and its salts
48.	4-Dimethylaminoazobenzene
49.	4-Nitrobiphenyl
50.	Beta-Propiolactone

CLASS C : Based on hazardous Characteristics

Apart from the concentration limit given above, the substances or wastes shall be classified as hazardous waste if it exhibits any of the following characteristics due to the presence of any hazardous constituents:

Class C1: Flammable - A waste exhibits the characteristic of flammability or ignitability if a representative sample of the waste has any of the following properties, namely:-

- (i) flammable liquids, or mixture of liquids, or liquids containing solids in solution or suspension (for example, paints, varnishes, lacquers, etc; but not including substances or wastes otherwise classified on account of their dangerous characteristics), which give off a flammable vapour at temperature less than 60°C. This flash point shall be measured as per ASTM D 93-79 closed-cup test method or as determined by an equivalent test method published by Central Pollution Control Board;
- (ii) it is not a liquid and is capable, under standard temperature and pressure, of causing fire through friction, absorption of moisture or spontaneous chemical changes and, when ignited, burns vigorously and persistently creating a hazard;
- (iii) it is an ignitable compressed gas;
- (iv) It is an oxidizer and for the purposes of characterisation is a substance such as a chlorate, permanganate, inorganic peroxide, or a nitrate, that yields oxygen readily to stimulate the combustion of organic matter.

Class C2: Corrosive- A waste exhibits the characteristic of corrosivity if a representative sample of the waste has either of the following properties, namely:-

- (i) it is aqueous and has a pH less than or equal to 2 or greater than or equal to 12.5;
- (ii) it is a liquid and corrodes steel (SAE 1020) at

a rate greater than 6.35 mm per year at a test temperature of 55 °C;

- (iii) it is not aqueous and, when mixed with an equivalent weight of water, produces a solution having a pH less than or equal to 2 or greater than or equal to 12.5;
- (iv) it is not a liquid and, when mixed with an equivalent weight of water, produces a liquid that corrodes steel (SAE1020) at a rate greater than 6.35 mm per year at a test temperature of 55 °C.

Note:

For the purpose of determining the corrosivity, the Bureau of Indian Standard 9040 C method for pH determination, NACE TM 01 69 : Laboratory Corrosion Testing of Metals and EPA 1110A method for corrosivity towards steel (SAE1020) to establish the corrosivity characteristics shall be adopted.

Class C3: Reactive or explosive- A waste exhibits the characteristic of reactivity if a representative sample of the waste it has any of the following properties, namely:-

- (i) it is normally unstable and readily undergoes violent change without detonating;
- (ii) it reacts violently with water or forms potentially explosive mixtures with water;
- (iii) when mixed with water, it generates toxic gases, vapours or fumes in a quantity sufficient to present a danger to human health or the environment;
- (iv) it is a cyanide or sulphide bearing waste which, when exposed to pH conditions between 2 and 12.5, can generate toxic gases, vapours or fumes in a quantity sufficient to present a danger to human health or the environmental;
- (v) it is capable of detonation or explosive reaction if it is subjected to a strong initiating source or if heated under confinement;
- (vi) it is readily capable of detonation or explosive decomposition or reaction at standard temperature and pressure;
- (vii) it is a forbidden explosive.

Class C4: Toxic- A waste exhibits the characteristic of toxicity, if, :-

- (i) the concentration of the waste constituents listed in Class A and B (of this schedule) are equal to or more than the permissible limits prescribed therein;
- (ii) it has an acute oral LD50 less than 2,500 milligrams per kilogram;
- (iii) it has an acute dermal LD50 less than 4,300 milligrams per kilogram;
- (iv) it has an acute inhalation LC50 less than 10,000 parts per million as a gas or vapour;
- (v) it has acute aquatic toxicity with 50% mortality within 96 hours for zebra fish (*Brachidanio rerio*) at a concentration of 500 milligrams per litre in dilution water and test conditions as specified in BIS test method 6582 – 2001.
- (vi) it has been shown through experience or by any standard reference test- method to pose a hazard to human health or environment because of its carcinogenicity, mutagenicity, endocrine disruptivity, acute toxicity, chronic toxicity, bio-accumulative properties or persistence in the environment.

Class C5: Substances or Wastes liable to spontaneous combustion - Substances or Wastes which are liable to spontaneous heating under normal conditions encountered in transport, or to heating up on contact with air, and being then liable to catch fire.

Class C6: Substances or Wastes which, in contact with water emit flammable gases- Substances or Wastes which, by interaction with water, are liable to become spontaneously flammable or to give off flammable gases in dangerous quantities.

Class C7: Oxidizing - Substances or Wastes which, while in themselves not necessarily combustible, may, generally by yielding oxygen cause, or contribute to, the combustion of other materials.

Class C8: Organic Peroxides - Organic substances or Wastes which contain the bivalent O–O structure, which may undergo exothermic self-accelerating decomposition.

Class C9: Poisons (acute) - Substances or Wastes liable either to cause death or serious injury or to harm human health if swallowed or inhaled or by skin contact.

Class C10: Infectious substances - Substances or Wastes containing viable micro-organisms or their toxins which are known or suspected to cause disease in animals or humans.

Class C11: Liberation of toxic gases in contact with air or water - Substances or Wastes which, by interaction with air or water, are liable to give off toxic gases in dangerous quantities.

Class C12: Eco-toxic- Substances or Wastes which if released, present or may present immediate or delayed adverse impacts to the environment by means of bioaccumulation or toxic effects upon biotic systems or both.

Class C13: Capable, by any means, after disposal, of yielding another material, e.g., leachate, which possesses any of the characteristics listed above.

Hazardous and Other Wastes (Management and Transboundary Movement) Rules, 2016

SCHEDULE III

[See rules 3 (1) (17) (iii), 3 (23), 12, 13 and 14]

Part A

List of hazardous wastes applicable for import and export with Prior Informed Consent [Annexure VIII of the Basel Convention*]

Basel No.	Description of Hazardous Wastes
(1)	(2)
A1	Metal and Metal bearing wastes
A1010	Metal wastes and waste consisting of alloys of any of the following but excluding such wastes specifically listed in Part B and Part D <ul style="list-style-type: none"> • Antimony • Cadmium • Lead • Tellurium
A1020	Waste having as constituents or contaminants, excluding metal wastes in massive form, any or the following: <ul style="list-style-type: none"> • Antimony, antimony compounds • Cadmium, cadmium compounds • Lead, lead compounds • Tellurium, tellurium compounds
A1040	Waste having metal carbonyls as constituents
A1050	Galvanic sludges
A1070	Leaching residues from zinc processing, dust and sludges such as jarosite, hematite, etc.
A1080	Waste zinc residues not included in Part B, containing lead and cadmium in concentrations sufficient to exhibit hazard characteristics indicated in Part C
A1090	Ashes from the incineration of insulated copper wire
A1100	Dusts and residues from gas cleaning systems of copper smelters
A1120	Waste sludges, excluding anode slimes, from electrolyte purification systems in copper electrorefining and electrowinning operations
A1140	Waste cupric chloride and copper cyanide catalysts not in liquid form note the related entry in Schedule VI
A1150	Precious metal ash from incineration of printed circuit boards not included in Part B

A1160	Waste lead acid batteries, whole or crushed
A1170	Unsorted waste batteries excluding mixtures of only Part B batteries. Waste batteries not specified in Part B containing constituents mentioned in Schedule II to an extent to render them hazardous
A2	Wastes containing principally inorganic constituents, which may contain metals and organic materials
A2010	Glass waste from cathode-ray tubes and other activated glasses
A2030	Waste catalysts but excluding such wastes specified in Part B
A3	Wastes containing principally organic constituents, which may contain metals and inorganic materials
A3010	Waste from the production or processing of petroleum coke and bitumen
A3020	Waste mineral oils unfit for their originally intended use
A3050	Wastes from production, formulation and use of resins, latex, plasticizers, glues or adhesives excluding such wastes specified in Part B (B4020)
A3120	Fluff-light fraction from shredding
A3130	Waste organic phosphorus compounds
A4	Wastes which may contain either inorganic or organic constituents
A4010	Wastes from the production, preparation and use of pharmaceutical products but excluding such waste specified in Part B
A4040	Wastes from the manufacture, formulation and use of wood-preserving chemicals (does not include wood treated with wood preserving chemicals)
A4070	Waste from the production, formulation and use of inks, dyes, pigments, paints, lacquers, varnish excluding those specified in Part B (B4010)
A4100	Wastes from industrial pollution control devices for cleaning of industrial off-gases but excluding such wastes specified in Part B
A4120	Wastes that contain, consist of or are contaminated with peroxides.
A4130	Wastes packages and containers containing Schedule II constituents in concentration sufficient to exhibit Part C of Schedule III hazard characteristics.
A4140	Waste consisting of or containing off specification or outdated chemicals (unused within the period recommended by the manufacturer) corresponding to constituents mentioned in Schedule II and exhibiting Part C of Schedule III hazard characteristics.
A4160	Spent activated carbon not included in Part B, B2060

***This List is based on Annexure VIII of the Basel Convention on Transboundary Movement of Hazardous Wastes and comprises of wastes characterized as hazardous under Article I, paragraph 1(a) of the Convention. Inclusion of wastes on this list does not preclude the use of hazard.**

Characteristics given in Annexure VIII of the Basel Convention (Part C of this Schedule) to demonstrate that the wastes are not hazardous. Hazardous wastes in Part-A are restricted and cannot be allowed to be imported without permission from the Ministry of Environment, Forest and Climate Change and the Directorate General of Foreign Trade license, if applicable.

Part B

List of other wastes applicable for import and export and not requiring Prior Informed Consent [Annex IX of the Basel Convention*]

Basel No.	Description of wastes
(1)	(2)
B1	Metal and metal-bearing wastes
B1010	Metal and metal-alloy wastes in metallic, non-dispersible form:
	Thorium scrap
	Rare earths scrap
B1020	Clean, uncontaminated metal scrap, including alloys, in bulk finished form (sheet, plates, beams, rods, etc.), of:
	• Antimony scrap
	• Beryllium scrap
	• Cadmium scrap
	• Lead scrap (excluding lead acid batteries)
	• Selenium scrap
	• Tellurium scrap
B1030	Refractory metals containing residues
B1031	Molybdenum, tungsten, titanium, tantalum, niobium and rhenium metal and metal alloy wastes in metallic dispersible form (metal powder), excluding such wastes as specified in Part A under entry A1050, Galvanic sludges
B1040	Scrap assemblies from electrical power generation not contaminated with lubricating oil, PCB or PCT to an extent to render them hazardous
B1050	Mixed non-ferrous metal, heavy fraction scrap, containing cadmium, antimony, lead & tellurium mentioned in Schedule II in concentrations sufficient to exhibit Part C characteristics
B1060	Waste selenium and tellurium in metallic elemental form including powder
B1070	Waste of copper and copper alloys in dispersible form, unless they contain any of the constituents mentioned in Schedule II to an extent that they exhibit Part C characteristics
B1080	Zinc ash and residues including zinc alloys residues in dispersible form unless they contain any of the constituents mentioned in Schedule II in concentration such as to exhibit Part C characteristics
B1090	Waste batteries conforming to a standard battery specification, excluding those made with lead, cadmium or mercury
B1100	Metal bearing wastes arising from melting, smelting and refining of metals:
	• Slags from copper processing for further processing or refining containing arsenic, lead or cadmium
	• Slags from precious metals processing for further refining
	• Wastes of refractory linings, including crucibles, originating from copper smelting
	• Tantalum-bearing tin slags with less than 0.5% tin
B1110	Used Electrical and electronic assemblies other than those listed in Part D of Schedule III
	Electronic assemblies consisting only of metals or alloys

	Waste electrical and electronic assemblies or scrap (including printed circuit boards) not containing components such as accumulators and other batteries included in Part A of Schedule III, mercury-switches, glass from cathode-ray tubes and other activated glass and PCB-capacitors, or not contaminated with Schedule II constituents such as cadmium, mercury, lead, polychlorinated biphenyl) or from which these have been removed, to an extent that they do not possess any of the characteristics contained in Part C of Schedule III (note the related entry in Schedule VI, A1180)
B1120	Spent catalysts excluding liquids used as catalysts, containing any of: Transition metals, excluding waste catalysts (spent catalysts, liquid used catalysts or other catalysts) in Part A and Schedule VI: - Scandium - Titanium - Vanadium - Chromium - Manganese - Iron - Cobalt - Nickel - Copper - Zinc - Yttrium - Zirconium - Niobium - Molybdenum - Hafnium - Tantalum - Tungsten - Rhenium Lanthanides (rare earth metals): - Lanthanum - Cerium
	- Praseodymium - Neodymium - Samarium - Europium - Gadolinium - Terbium - Dysprosium - Holmium - Erbium - Thulium - Ytterbium - Lutetium
B1130	Cleaned spent precious metal bearing catalysts
B1140	Precious metal bearing residues in solid form which contain traces of inorganic cyanides
B1150	Precious metals and alloy wastes (gold , silver, the platinum group but not mercury) in a dispersible form, non-liquid form with appropriate packaging and labelling
B1160	Precious metal ash from the incineration of printed circuit boards (note the related entry in Part A A1150)
B1170	Precious metal ash from the incineration of photographic film
B1180	Waste photographic film containing silver halides and metallic silver
B1190	Waste photographic paper containing silver halides and metallic silver
B1200	Granulated slag arising from the manufacture of iron and steel
B1210	Slag arising from the manufacture of iron and steel including slags as a source of Titanium dioxide and Vanadium
B1220	Slag from zinc production, chemically stabilised, having a high iron content (above 20%) and processed according to industrial specifications mainly for construction
B1230	Mill scale arising from the manufacture of iron and steel
B1240	Copper Oxide mill-scale
B2	Wastes containing principally inorganic constituents, which may contain metals and organic materials
B2010	Wastes from mining operations in non-dispersible form:

	- Natural graphite waste
	- Slate wastes
	- Mica wastes
	- Leucite, nepheline and nepheline syenite waste
	- Feldspar waste
	- Fluorspar waste
	- Silica wastes in solid form excluding those used in foundry operations
B2020	Glass wastes in non-dispersible form: Cullet and other waste and scrap of glass except for glass from cathode-ray tubes and other activated glasses
B2030	Ceramic wastes in non-dispersible form: Cermet wastes and scrap (metal ceramic composites) Ceramic based fibres
B2040	Other wastes containing principally inorganic constituents: <ul style="list-style-type: none"> • Partially refined calcium sulphate produced from flue gas desulphurization (FGD) • Waste gypsum wallboard or plasterboard arising from the demolition of buildings • Slag from copper production, chemically stabilized, having a high iron content (above 20%) and processed according to industrial specifications mainly for construction and abrasive applications • Sulphur in solid form • Limestone from production of calcium cyanamide (pH<9) • Sodium, potassium, calcium chlorides • Carborundum (silicon carbide) • Broken concrete • Lithium-tantalum and lithium-niobium containing glass scraps
B2060	Spent activated carbon not containing any of Schedule II constituents to the extent they exhibit Part C characteristics, for example, carbon resulting from the treatment of potable water and processes of the food industry and vitamin production (note the related entry in Part A A4160)
B2070	Calcium fluoride sludge
B2080	Waste gypsum arising from chemical industry processes not included in Schedule VI (note the related entry in A2040)
B2090	Waste anode butts from steel or aluminium production made of petroleum coke or bitumen and cleaned to normal industry specifications (excluding anode butts from chlor alkali electrolyses and from metallurgical industry)
B2100	Waste hydrates of aluminium and waste alumina and residues from alumina production, excluding such materials used for gas cleaning, flocculation or filtration processes
B2130	Bituminous material (asphalt waste) from road construction and maintenance, not containing tar (note the related entry in Schedule VI, A3200)
B3	Wastes containing principally organic constituents, which may contain metals and inorganic materials
B3027	Self-adhesive label laminate waste containing raw materials used in label material production

B3030	<p>Textile wastes</p> <p>The following materials, provided they are not mixed with other wastes and are prepared to a specification:</p> <ul style="list-style-type: none"> • Silk waste (including cocoons unsuitable for reeling, yarn waste and garnetted stock) <ul style="list-style-type: none"> ~ not carded or combed ~ other • Waste of wool or of fine or coarse animal hair, including yarn waste but excluding garnetted stock <ul style="list-style-type: none"> ~ noils of wool or of fine animal hair ~ other waste of wool or of fine animal hair ~ waste of coarse animal hair • Cotton waste (including yarn waste and garnetted stock) <ul style="list-style-type: none"> ~ yarn waste (including thread waste) ~ garnetted stock ~ other • Flax tow and waste • Tow and waste (including yarn waste and garnetted stock) of true hemp (<i>Cannabis sativa</i> L.) • Tow and waste (including yarn waste and garnetted stock) of jute and other textile bast fibres (excluding flax, true hemp and ramie) • Tow and waste (including yarn waste and garnetted stock) of sisal and other textile fibres of the genus <i>Agave</i> • Tow, noils and waste (including yarn waste and garnetted stock) of coconut • Tow, noils and waste (including yarn waste and garnetted stock) of abaca (<i>Manila hemp</i> or <i>Musa textilis</i> Nee) • Tow, noils and waste (including yarn waste and garnetted stock) of ramie and other vegetable textile fibres, not elsewhere specified or included • Waste (including noils, yarn waste and garnetted stock) of man- made fibres <ul style="list-style-type: none"> ~ of synthetic fibres ~ of artificial fibres • Worn clothing and other worn textile articles • Used rags, scrap twine, cordage, rope and cables and worn out articles of twine, cordage, rope or cables of textile materials <ul style="list-style-type: none"> ~ sorted ~ other
B3035	Waste textile floor coverings, carpets
B3040	<p>Rubber Wastes</p> <p>The following materials, provided they are not mixed with other wastes:</p> <p>Waste and scrap of hard rubber (e.g., ebonite)</p> <p>Other rubber wastes (excluding such wastes specified elsewhere)</p>
B3050	<p>Untreated cork and wood waste:</p> <p>Wood waste and scrap, whether or not agglomerated in logs, briquettes, pellets or similar forms</p> <p>Cork waste: crushed, granulated or ground cork</p>
B3060	<p>Wastes arising from agro-food industries provided it is not infectious:</p> <ul style="list-style-type: none"> • Wine lees • Dried and sterilized vegetable waste, residues and by-products, whether or not in the form of pellets, of a kind used in animal feeding, not elsewhere specified or included • Degras: residues resulting from the treatment of fatty substances or animal or vegetable waxes • Waste of bones and horn-cores, unworked, defatted, simply prepared (but not cut to shape), treated with acid or degelatinised • Fish waste • Cocoa shells, husks, skins and other cocoa waste • Other wastes from the agro-food industry excluding by-products which meet national and international requirements and standards for human or animal consumption

B3070	The following wastes: <ul style="list-style-type: none"> • Waste of human hair • Waste straw • Deactivated fungus mycelium from penicillin production to be used as animal feed
B3080	Waste parings and scrap of rubber
B3090	Paring and other wastes of leather or of composition leather not suitable for the manufacture of leather articles, excluding leather sludges, not containing hexavalent chromium compounds and biocides (note the related entry in Schedule VI, A3100)
B3100	Leather dust, ash, sludges or flours not containing hexavalent chromium compounds or biocides (note the related entry in Schedule VI, A3090)
B3110	Fellmongery wastes not containing hexavalent chromium compounds or biocides or infectious substances (note the related entry in Schedule VI, A3110)
B3120	Wastes consisting of food dyes
B3130	Waste polymer ethers and waste non-hazardous monomer ethers incapable of forming peroxides
B3140	Waste pneumatic and other tyres, excluding those which do not lead to resource recovery, recycling, reclamation but not for direct reuse
B4	Wastes which may contain either inorganic or organic constituents
B4010	Wastes consisting mainly of water-based or latex paints, inks and hardened varnishes not containing organic solvents, heavy metals or biocides to an extent to render them hazardous (note the related entry in Part A, A4070)
B4020	Wastes from production, formulation and use of resins, latex, plasticizers, glues or adhesives, not listed in Part A, free of solvents and other contaminants to an extent that they do not exhibit Part C characteristics (note the related entry in Part A, A3050)
B4030	Used single-use cameras, with batteries not included in Part A

* This list is based on Annexure IX of the Basel Convention on Transboundary Movement of Hazardous Wastes and comprises of wastes not characterized as hazardous under Article-I of the Basel Convention. The wastes in Part- B are restricted and cannot be allowed to be imported without permission from the Ministry of Environment, Forest and Climate Change and the Directorate General of Foreign Trade license, if applicable.

Note:

- (1) Copper dross containing copper greater than 65% and lead and Cadmium equal to or less than 1.25% and 0.1% respectively; spent cleaned metal catalyst containing copper; and copper reverts, cake and residues containing lead and cadmium equal to or less than 1.25% and 0.1% respectively are allowed for import without Director General of Foreign Trade license to units (actual users) authorised by State Pollution Control Board and with the Ministry of Environment, Forest and Climate Change's permission. Copper reverts, cake and residues containing lead and cadmium greater than 1.25% and 0.1% respectively are under restricted category for which import is permitted only against Director General of Foreign Trade license for the purpose of processing or reuse by units permitted with the Ministry of Environment, Forest and Climate Change (actual users).
- (2) Zinc ash or skimmings in dispersible form containing zinc more than 65% and lead and cadmium equal to or less than 1.25% and 0.1% respectively and spent cleaned metal catalyst containing zinc are allowed for import without Director General of Foreign Trade license to units authorised by State Pollution control Board, Ministry of Environment, Forest and Climate Change's permission (actual users) upto an annual quantity limit indicated in registration letter. Zinc ash and skimmings containing less than 65% zinc and lead and cadmium equal to or more than 1.25% and 0.1% respectively and hard zinc spelter and brass dross containing lead greater than 1.25% are under restricted category for which import is permitted against Director General of Foreign Trade license and only for purpose of processing or reuse by units registered with the Ministry of Environment Forest and Climate Change (actual users).

Part C

List of Hazardous Characteristics

Code Characteristic

H 1 Explosive

An explosive substance or waste is a solid or liquid substance or waste (or mixture of substances or wastes) which is in itself capable by chemical reaction of producing gas at such a temperature and pressure and at such a speed as to cause damage to the surrounding.

H 3 Flammable liquids

The word “flammable” has the same meaning as “inflammable”. Flammable liquids are liquids, or mixtures of liquids, or liquids containing solids in solution or suspension (for example, paints, varnishes, lacquers, etc. but not including substances or wastes otherwise classified on account of their dangerous characteristics) which give off a flammable vapour at temperatures of not more than 60.5°C, closed-cup test, or not more than 65.6°C, open-cup test. (Since the results of open-cups tests and of closed-cup tests are not strictly comparable and even individual results by the same test are often variable, regulations varying from the above figures to make allowance for such differences would be within the spirit of this definition).

H 4.1 Flammable solids

Solids, or waste solids, other than those classed as explosives, which under conditions encountered in transport are readily combustible, or may cause or contribute to fire through friction.

H 4.2 Substances or wastes liable to spontaneous combustion

Substances or wastes which are liable to spontaneous heating under normal conditions encountered in transport, or to heating up on contact with air, and being then liable to catch fire.

H 4.3 Substances or wastes which, in contact with water emit flammable gases

Substances or wastes which, by interaction with water, are liable to become spontaneously flammable or to give off flammable gases in dangerous quantities.

H 5.1 Oxidizing

Substances or wastes which, while in themselves not necessarily combustible, may, generally by yielding oxygen cause, or contribute to, the combustion or other materials.

H 5.2 Organic Peroxides

Organic substances or wastes which contain the bivalent-o-o-structure are thermally unstable substances which may undergo exothermic self-accelerating decomposition.

H 6.1 Poisons (acute)

Substances or wastes liable either to cause death or serious injury or to harm human health if swallowed or inhaled or by skin contact.

H 6.2 Infectious substances

Substances or wastes containing viable micro-organisms or their toxins which are known or suspected to cause disease in animals or humans.

H 8 Corrosives

Substances or wastes which, by chemical action, will cause severe damage when in contact with living tissue, or, in the case of leakage, will materially damage, or even destroy, other goods or the means of transport; they may also cause other hazards.

H 10 Liberation of toxic gases in contact with air or water

Substances or wastes which, by interaction with air or water, are liable to give off toxic gases in dangerous quantities.

H 11 Toxic (delayed or chronic)

Substances or wastes which, if they are inhaled or ingested or if they penetrate the skin, may involve delayed or chronic effects, including carcinogenicity).

H 12 Eco-toxic

Substances or wastes which if released, present or may present immediate or delayed adverse impacts to the environment by means of bioaccumulation or toxic effects upon biotic systems or both.

H 13 Capable

By any means, after disposal, of yielding another material, e.g., leachate, which possesses any of the characteristics listed above.

Part D

List of other wastes applicable for import and export without permission from Ministry of Environment, Forest and Climate Change [Annex IX of the Basel Convention*]

Basel No.	Description of wastes
(1)	(2)
B1	Metal and metal-bearing wastes
B1010	Metal and metal-alloy wastes in metallic, non-dispersible form :
	Precious metals (gold, silver, platinum but not mercury) * *
	Iron and steel scrap * *
	Nickel scrap * *
	Aluminium scrap* *
	Zinc scrap * *
	Tin scrap * *
	Tungsten scrap * *
	Molybdenum scrap * *
	Tantalum scrap * *
	Cobalt scrap * *
	Bismuth scrap * *
	Titanium scrap * *
	Zirconium scrap * *
	Manganese scrap * *
	Germanium scrap * *
	Vanadium scrap * *
	Hafnium scrap * *
	Indium scrap * *
	Niobium scrap * *
	Rhenium scrap * *
	Gallium scrap * *
	Magnesium scrap * *
	Copper scrap * *
	Chromium scrap * *

B1050	Mixed non-ferrous metal, heavy fraction scrap, containing metals other than specified in Part B1050 and not containing constituents mentioned in Schedule II in concentrations sufficient to exhibit Part C characteristics* *
B1100	Metal bearing wastes arising from melting, smelting and refining of metals:
	Hard Zinc spelter * *
	Zinc-containing drosses * *: <ul style="list-style-type: none"> ~ Galvanizing slab zinc top dross (>90% Zn) ~ Galvanizing slab zinc bottom dross (>92% Zn) ~ Zinc die casting dross (>85% Zn) ~ Hot dip galvanizers slab zinc dross (batch) (>92% Zn) ~ Zinc skimmings
	Aluminium skimmings (or skims) excluding salt slag
B1110	Electrical and electronic assemblies (including printed circuit boards, electronic components and wires) destined for direct reuse and not for recycling or final disposal
	Used electrical and electronic assemblies imported for repair and to be re- exported back after repair within one year of import * * *
	Used electrical and electronic assemblies imported for rental purpose and re-exported back within one year of import
	Used electrical and electronic assemblies exported for repair and to be re- import after repair
	Used electrical and electronic assemblies imported for testing, research and development, project work purposes and to be re-exported back within a period of three years from the date of import * * *
	Spares imported for warranty replacements provided equal number of defective or non-functional parts are exported back within one year of the import * * *
	Used electrical and electronic assemblies imported by Ministry of Defence, Department of Space and Department of Atomic Energy * * *
	Used electrical and electronic assemblies (not in bulk; quantity less than or equal to three) imported by the individuals for their personal uses
	Used Laptop, Personal Computers, Mobile, Tablet up to 01 number each imported by organisations in a year
	Used electrical and electronic assemblies owned by individuals and imported on transfer of residence
	Used multifunction print and copying machines (MFDs)* * * *
	Used electrical and electronic assemblies imported by airlines for aircraft maintenance and remaining either on board or under the custodianship of the respective airlines warehouses located on the airside of the custom bonded areas.
B3	Wastes containing principally organic constituents, which may contain metals and inorganic materials
B3020	Paper, paperboard and paper product wastes * *
B3140	Aircraft Tyres exported to Original Equipment Manufacturers for re-treading and re-imported after re-treading by airlines for aircraft maintenance and remaining either on board or under the custodianship of the respective airlines warehouses located on the airside of the custom bonded areas

Note:

* This list is based on Annexure IX of the Basel Convention on Transboundary Movement of Hazardous Wastes and comprises of wastes not characterized as hazardous under Article-I of the Basel Convention.

** Import permitted in the country to the actual user or to the trader on behalf of the actual users authorised by SPCB on one time basis and subject to verification of documents specified in Schedule VIII of these rules by the Custom Authority.

*** Import permitted in the country only to the actual users from Original Equipment Manufacturers (OEM) and subject to verification of documents specified in Schedule VIII of these rules by the Custom Authority.

**** Import permitted in the country to the actual users or trader on behalf of the actual user in accordance with the documents required and verified by the Custom Authority as specified under Schedule VIII of these rules. The policy for free trade for multifunction print and copying machine to be reviewed once the MFDs are domestically manufactured.

All other wastes listed in Part D of Schedule III having no "Stars" are permitted without any documents from MoEF&CC subject to compliance of the conditions of the Customs Authority, if any.

List of Technology and Service Providers in Onsite and Decentralized Solid Waste Management

S No.	Name of the Company	Contact Person Name & Address	Contact Details
I			
TRIPOT COMPOSTING			
	Hi-Tech Bio Fertilizers India	Mr. Joseph J Moonjely No. 34/1841, A-1, Edappally Edappally Ernakulum - 682024 Kerala, India	Tel. 094471 33363 Mail: info@cleancity.in
	Daily Dump	Ms. Poonam Bir Kasturi 1163, 1st Cross, Off 12th Main, Near Sony Center, HAL 2nd Stage, Bangalore 560008, INDIA.	Tel: +91 80 41157311 +91 99164 26661 +91 98863 63882 hello@dailydump.org
	Green Essentials	Mr. Karan Manral Ug 1 Maina Maina Goa - 403501 Goa, India	Tel: +91 8087000708 info@greenessentials.in
	Parisudh Eco Concepts Private Limited	Mr. T. Jayaraj 2/307, KRS Complex, BPL Junction Koottupatha, Palakkad-60067 Kerala, India	Tel: 04912570470 Mob: +91 9446040470
II			
KITCHEN BIN COMPOSTING			
	StoneSoup	Ms. Malini No. 37, First Block, Main Koramangala, Bengaluru-560034, Karnataka, India	Tel: 080 4121 4957
	Neem Enviro	Mr. Parmatma Prasad Gupta 205, Bhawani Industrial Estate, Hare Krishna Road, Opposite Main Gate Of IIT Bombay Andheri West Mumbai - 400076 Maharashtra, India	Tel: +91 9819913642 neemenviro@gmail.com
	Greentech Life	Mr. Vinay Kulkarni Level II, Prestige Omega, No. 104, EPIP Zone Whitefield Bengaluru - 560066 Karnataka, India	Tel: +91 8067710997 support@greentechlife.in
III			
BLUE HDPE DIGESTER			
	Sudh-Labh Solutions Private Limited	Mr. Nikhin/Ramanan No 125, 3 rd Floor, 3 rd Cross, 2 nd Stage, Arekere Mico Layout, Bannerghata Road, Bangalore 560076	Nikhin: +91 7090798830 Ramanan: +91 9880710830 info@sudh-labh.in
IV			
ECO POT			
	Neucotechs	Mr. Vijayann 19, 1 st Parthasarathy Nagar Chennai-88	Mobile: +91 9150452803, 8668187859 drv@neucotechs.com; vijayanrd@gmail.com

V DRUM COMPOSTING SYSTEM			
	Neem Enviro	Mr. Parmatma Prasad Gupta 205, Bhawani Industrial Estate, Hare Krishna Road, Opposite Main Gate of IIT Bombay Powai, Andheri West, Mumbai-400076 Maharashtra, India	Phone No: 08048700405, 9819913642 neemenviro@gmail.com
	Jayaa Agro Foods	Mr. Shekhar No. 36, SS Akshaya, 2nd Cross, Behind Kensri School Defence Enclave, Phase II, HA Farm Post, Marianna, Bengaluru-560024, Karnataka, India	+9844796120 jayaabio@gmail.com
	Go Green Solutions	Mr. Ketan Puranik No. 37, Radio Colony, Residency Area, Indore-452001, Madhya Pradesh, India	+08071744708
VI ROTARY DRUM COMPOSTING SYSTEM			
	Pune Renewable Energy Systems	Mr. Amod Deshmukh Plot No. J. 164, S Block, M.I.D.C, Bhosari, Bhosari Pune - 411026 Maharashtra, India	Tel.: +91-98220 39376 Email: info@pune-renewable-energy.com
	SWM Bengaluru	Mr. Deepak NK No. 43/1, 7th Cross, Om Shakthi Temple Road Hegganahalli Bengaluru - 560022 Karnataka, India	Tel: 08048088014
	Spinform Plastics Private Limited	Mr. Kishor Rathi Spinform Plastics Pvt. Ltd. B-37-2, M.I.D.C., Chikalthana Near Power Room, Aurangabad - 431006, Maharashtra, India	Tel: +91-8855813902 +91-9822060075
VII VERMICOMPOSTING			
	Live-alive	Ms. Aditi Varsoda, Pethapur -Mahudi Road, Ahmedabad - 382845, Gujarat, India	Tel. 08049441235
	Alaknanda Technologies Private Limited	Ms. Rohini Chaudhary No. 15, Good Will Harmony, Sector 19, Plot No 76 Airoli, Navi Mumbai - 400708, Maharashtra, India	Tel. +917506122713, +918802154311
	Waste Pro	Ms. Phani Trivedi No. 54, Swapnlok Apartments, Law Garden, Ahmedabad-382006, Gujarat, India	
	Parisudh Eco Concepts Private Limited	Mr. T. Jayaraj 2/307, KRS Complex, BPL Junction Koottupatha, Palakkad-60067 Kerala, India	Tel: 04912570470 Mob: +91 9446040470

VIII			
PORTABLE HOUSEHOLD BIOBIN			
	Hi-Tech Bio Fertilizers India	Mr. Joseph J Moonjely No. 34/1841, A-1, Edappally Edappally Ernakulum - 682024 Kerala, India	Tel. 094471 33363 Mail: info@cleancity.in
IX			
AEROBIC BIN COMPOSTING			
	Parisudh Eco Concepts Private Limited	Mr. T. Jayaraj 2/307, KRS Complex, BPL Junction Koottupatha, Palakkad-60067 Kerala, India	Tel: 04912570470 Mob: +91 9446040470
	Vivesty Green Co.	Mr. Ajai Kumar F-6, 49/1380, N.M. Complex, C.H. Cross Road, West Nadakkavu, Kozhikode-673011, Kerala, India	Tel: +91 9447-894279 +91 9400-222966 green@vivesty.com
X			
ORGANIC WASTE COMPOSTING MACHINE			
	Excel Industries Limited	Mr. Harshad Gandhi 184-187, S.V. Road Jogeshwari (West) Mumbai-400102	Tel: +91-22-6646-4342 Email: owc@excelind.com
	Eleme Eco-Solutionsnto Pvt. Ltd	Mr. Ashwini 1/1 Ketaki Apartments, Tulshibaugwale Colony, Sahakar Nagar 2, Pune, Pune-411009, Maharashtra, India	
	Ecoman Environ Solution Private Limited	Mr. Sushil Kumbhar Gate No:189, Bhalekar Chowk, Jyotiba Nagar, Talwade, Pimpri-Chinchwad, Pune-412114, Maharashtra, India	Tel: +91-20-32535122 +917720999222 Email: inquiries@ecomanenviro.com
XI			
BYOBIN			
	Pelican Biotech	Mr. Manoj Cn 1/ 77, VII/ 390, NC John Estate Kuthiathode., Alappuzha-688533, Kerala, India	Tel: +91-478-2560206 contact@pelicanbiotech.com
XII			
ORBIN			
	Orbin	Ms. Anjana Iyer One Hop Organics Pvt. Ltd. #701, Brigade Rubix, 20, HMT Main Road, Yeswanthpur, Bangalore - 560 013, India	Tel: +91 72594 04888 contact@orbin.in
XIII			
SOLAR COMPOSTER			
	Shree Skanda Solar Systems	No.48/37, Dubasipalya, R V Road, Bangalore - 560059, Near Ghnana Bodhini School	Email: ysnagendra7@gmail.com Phone: +91 9886197121

	Klimrus Sustainable Solution Pvt. Ltd.	Mr. Rutvick Pedamkar Shop No 2, Avantisagar Building, Arjun Sagar Complex, Near Telawane Tower, Badlapur East, Thane-421503, Maharashtra, India	Tel: +91 8048725745
XIV	AAGA		
	Daily Dump	Ms. Poonam Bir Kasturi 1163, 1st Cross, Off 12th Main, Near Sony Center, HAL 2nd Stage, Bangalore 560008, INDIA.	Tel: +91 80 41157311 +91 99164 26661 +91 98863 63882 hello@dailydump.org
XV	BOKASHI		
	Quantum Leap	57, Jyothi Nilaya, 6, 1st Cross Rd, Prathiba Industrial Estate, Kumaraswamy Layout, Bengaluru, Karnataka 560078	Email: sales.leaf@quantumleafguru.com Phone: +91 9035274764
	Pioneer Agro Industry	Mr. Suresh Kumar No. 14 C, Pudhur Main Road Peelamedu, Coimbatore-641004, Tamil Nadu, India	Email : pteagro@gmail.com Mobile : +91 999 499 4429
XVI	PLASTIC CRATES		
	Reap Benefit	Mr. Gautam Prakash/ Kuldeep Dantewadia 521, 20th Main Road, 4th T Block East, Pattabhirama Nagar, Jaya Nagar, Bengaluru, Karnataka 560041	Email: info@reapbenefit.in Phone: +91-99866 15136 / +91-98863 61805
XVII	FRP AEROBIC DIGESTER		
	Sudh labh	Mr. Ramanan No 125, 3rd Floor, 3rd Cross, 2nd Stage, Arekere Mico Layout, Bannerghatta Road, Bengaluru, Karnataka 560076	Email: info@sudh-labh.in Phone: +91 9964508833
XVIII	MARIGOLD		
	Prudent Ecosystems	Ms. Latha No.68, 4th C Cross, Magadi Main Road, Kamakshipalya, Vrushabhavathi nagar Bangalore KA 560079 IN	Tel: +91 9886003355 enquiry@prudentecosystems.com
XIX	SOIL AND HEALTH SWM CONSULTANT AERBI AND AEROBIC COMPOSTER		
	Soil and Health Solutions	Mr. Vasuki Iyengar	Tel: +91 9481352125, +919845690778 vasuki@soilandhealth.in
XX	WINDROW COMPOSTING		
	Myco Compost	Mr. Shivam 149/3, House No. 894/1, Ganesh nagar, Opposite Solapur, Janata Sahkari bank, Dhyari Pune, Maharastra-411041	+91 9604046983 koustubhyadre@yahoo.com
	Alfa Therm Limited	Mr. Harjot Chadha 6, Community Centre, Mayapuri Industrial Area Phase - I, New Delhi-110064 (INDIA),	Tel : +91-11-28115222, 28116222, 28114748 Fax : +91-11-28115396 Email : alfatherm@vsnl.com

	Excel Industries Limited	Mr. Saurabh Shah, 184-87, S.V. Road, Jogeshwari (West), Mumbai - 400 102, Maharashtra, India.	Email: excel.mumbai@excelind.com Tel.: 91 - 22 - 66464200 Fax: 91 - 22 - 26783657
XXI	ROTARY DRUM COMPOSTING (LARGE)		
	Pune Renewable Energy Systems	Mr. Amod Deshmukh Plot No. J. 164, S Block, M.I.D.C, Bhosari, Bhosari Pune - 411026 Maharashtra, India	Tel.: +91-98220 39376 Email: info@pune-renewable-energy.com
	SWM Bengaluru	Mr. Deepak NK No. 43/1, 7th Cross, Om Shakthi Temple Road Hegganahalli Bengaluru - 560022 Karnataka, India	Tel: 08048088014
	Spinform Plastics Private Limited	Mr. Kishor Rathi Spinform Plastics Pvt. Ltd. B-37-2, M.I.D.C., Chikalthana Near Power Room, Aurangabad - 431006, Maharashtra, India	Tel: +91-8855813902 +91-9822060075
XXII	VERMI COMPOSTER		
	Live-alive	Ms. Aditi Varsoda, Pethapur -Mahudi Road, Ahmedabad - 382845, Gujarat, India	Tel. 08049441235
	Alaknanda Technologies Private Limited	Ms. Rohini Chaudhary No. 15, Good Will Harmony, Sector 19, Plot No 76 Airoli, Navi Mumbai - 400708, Maharashtra, India	Tel. +917506122713, +918802154311
	Waste Pro	Ms. Phani Trivedi No. 54, Swapnlok Apartments, Law Garden, Ahmedabad-382006, Gujarat, India	
	Parisudh Eco Concepts Private Limited	Mr. T. Jayaraj 2/307, KRS Complex, BPL Junction Koottupatha, Palakkad-60067 Kerala, India	Tel: 04912570470 Mob: +91 9446040470
XXIII	TALL BOY		
	Riteways Enviro Private Limited	#43, 2nd Floor, 9th Cross, Sharadamba Nagar, Jalahalli Village, Bangalore 560013, Karnataka, India	T: +91 80 2345 2279 +91 9945.801.176 Email: solutions@rite-ways.com

Bibliography

- 1) Bruhat Bengaluru Mahanagara Palike (2017), "Bengaluru's SWM Information Manual - Part I: Overview".
- 2) Environment Canada Publications (2013), "Technical Document on Municipal Solid Waste Organics Processing", Government of Canada.
- 3) Indian Institute of Soil Science (2013), "Rapid Composting Methods", Indian Council of Agricultural Research, Bhopal, Madhya Pradesh.
- 4) Local Self Government Department, "Technical Handbook", Government of Kerala.
- 5) Ministry of Drinking Water and Sanitation (2015), "Technological Options for Solid and Liquid Waste Management in Rural Areas", Government of India.
- 6) Ministry of Environment, Forest and Climate Change (2016), "Bio-Medical Waste Management Rules, 2016", Government of India.
- 7) Ministry of Environment, Forest and Climate Change (2016), "Hazardous and Other Wastes (Management and Transboundary Movement) Rules, 2016", Government of India.
- 8) Ministry of Environment, Forest and Climate Change (2016), "Solid Waste Management Rules, 2016", Government of India.
- 9) Ministry of Housing and Urban Development (the erstwhile Ministry of Urban Development), "Municipal Solid Waste Management Manual- Part II", 2016, Government of India.
- 10) Tamil Nadu Agricultural University (2017), accessed on 27.12.2017 available at http://agritech.tnau.ac.in/org_farm/orgfarm_panchakavya.html.



NOTES

A series of horizontal dotted lines for taking notes.



...the ...

...the ...

...the ...

...the ...

...the ...

...the ...

...the ...

...the ...

...the ...

...the ...

...the ...

...the ...

...the ...

...the ...

...the ...

...the ...

...the ...

...the ...



**Ministry of Housing
and Urban Affairs**
Government of India



एक कदम स्वच्छता की ओर